

REDEKOP™

BLOCKAGE SENSOR
JOHN DEERE S600 & S700

INSTALLATION MANUAL

PRODUCT NUMBER: **850-007**

1 Deflector Plate Installation

Parts List:

SC422BL Blockage Sensor Deflector - Left (**AL**) Qty 1
SC422BR Blockage Sensor Deflector - Right (**AR**) Qty 1

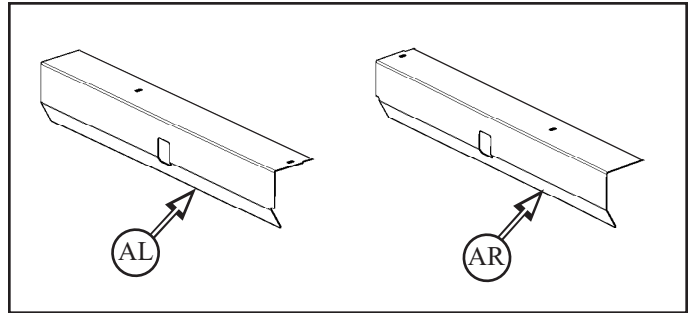

1.1 Remove chaff divider panel (**B**) from inside combine

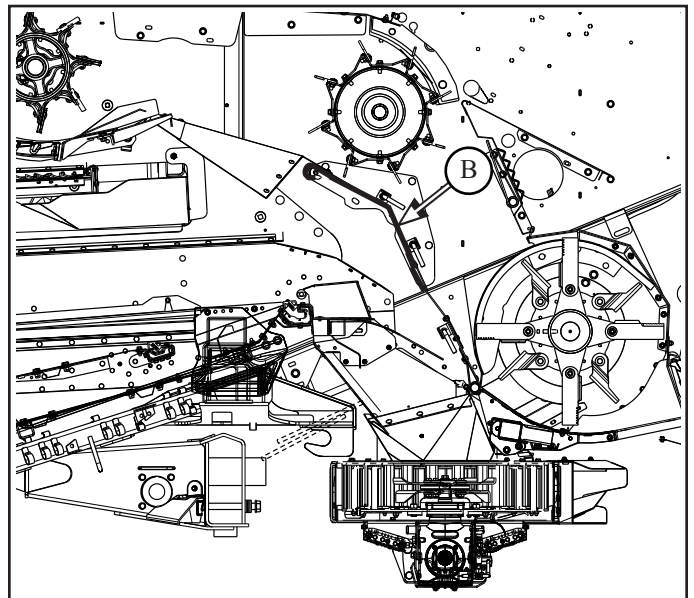
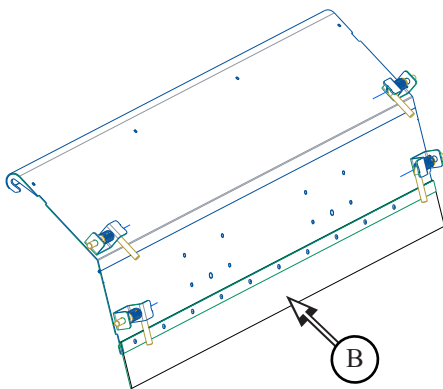

1.2 Remove the 4 upper knockouts (**B1**) x4 on the chaff divider panel (**B**)

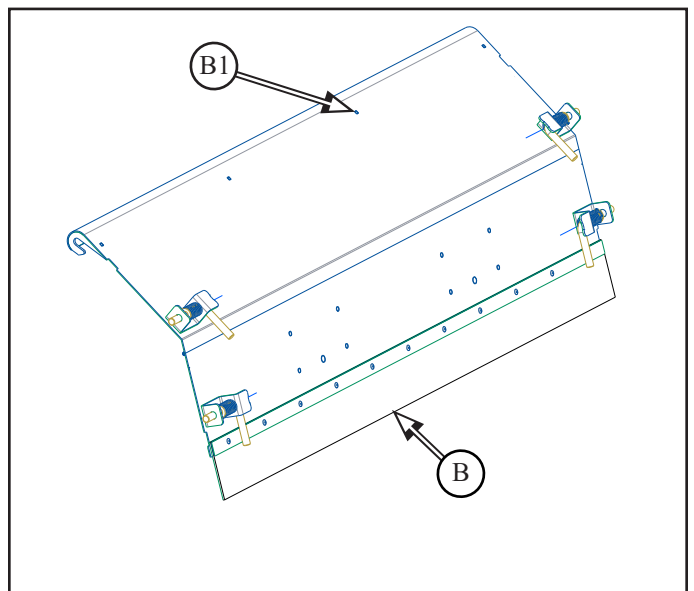

- 1.3** Install deflector plates (**AL & AR**) to the top of the chaff divider (**B**), with:
- M6 x 12 round head bolt and flange nut (**A1**) x4
 - ensure deflector plates are adjusted all the way against the round nose of the chaff divider panel
 - ensure heads of bolts are on top of panel

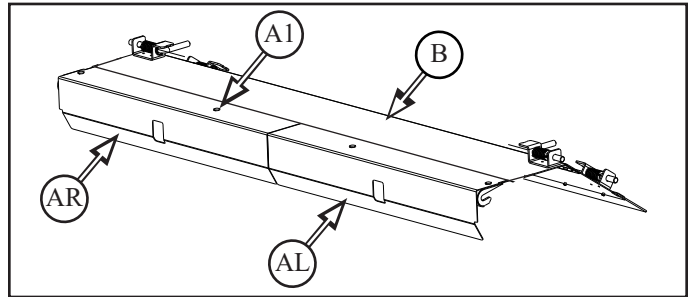
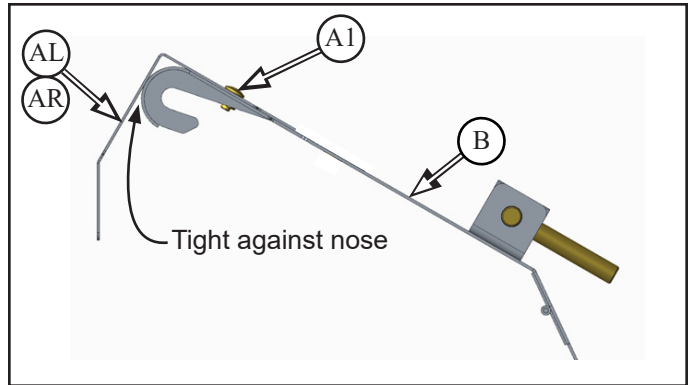

2 Optical Sensors Installation - S700 Series

Parts List:

SC421BAL	Blockage Sensor Receiver - Left (CL)	Qty 1
SC421BAR	Blockage Sensor Emitter - Right (CR)	Qty 1
SC421_Template	Drill Template S700 (D)	Qty 1
SC421_Template_2	Drill Template S600 (E)	Qty 1
RP1336	Hole Saw (F)	Qty 1
RP1362	Decal CHAFF Sense (M)	Qty 2

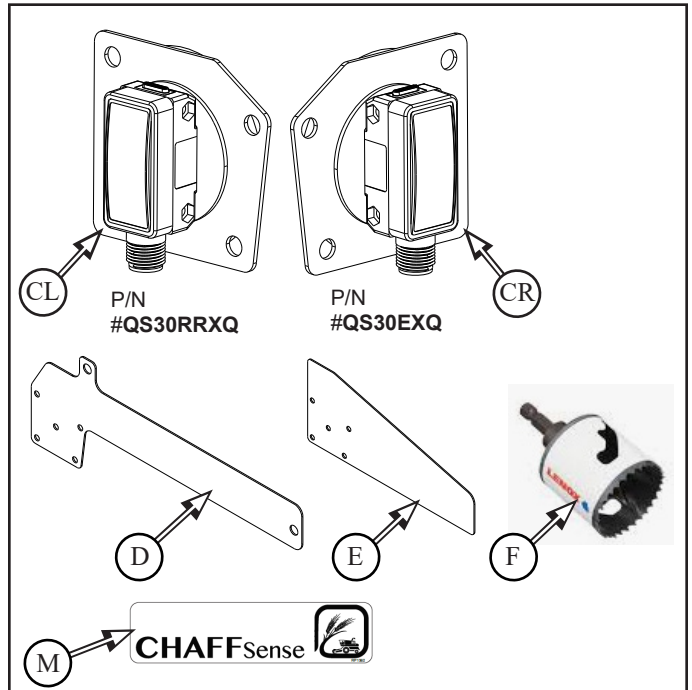

S700 Series

- 2.1** Remove nuts (**G1**) x2 from the chaff divider mounting plate bolts
- both sides

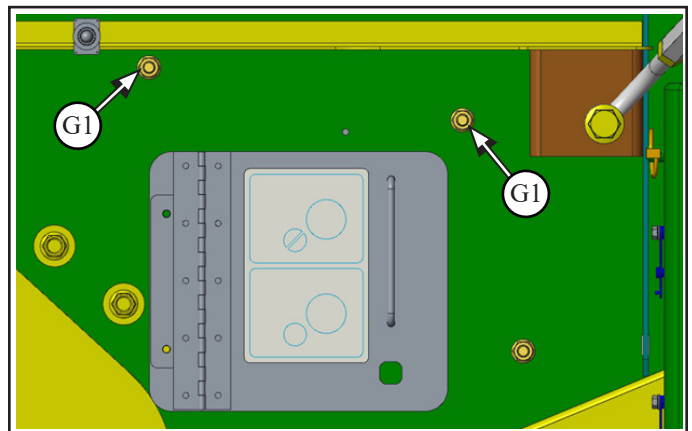

2.1.2 Install drill template (B) onto chaff divider mounting plate bolts (G1) x2

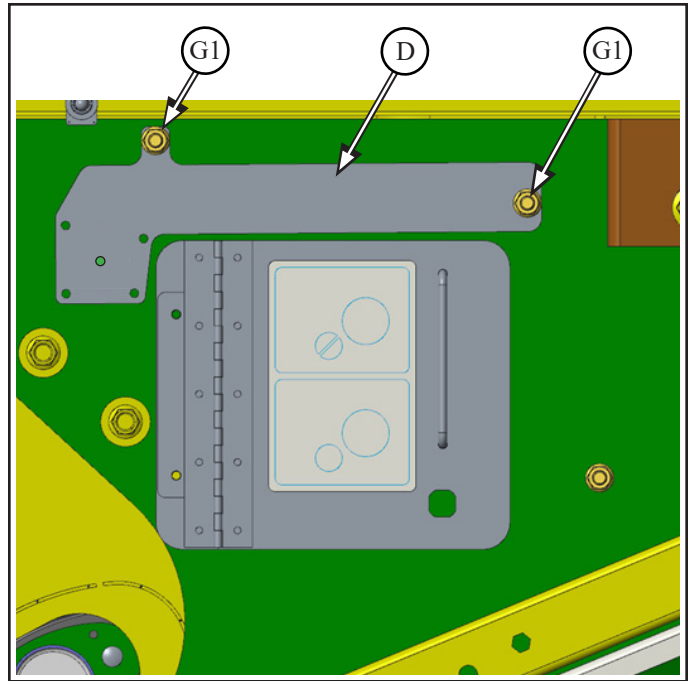

2.1.3 Using template, drill 6mm holes (D1) x5 through combine wall

2.1.3.1 Remove template (D)

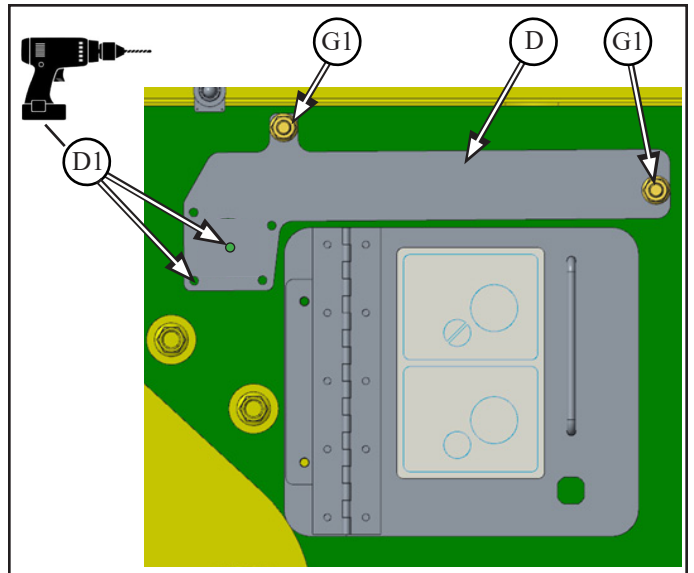

2.1.4 Drill 41mm hole (D2) with supplied hole saw (F) using pilot hole through combine wall

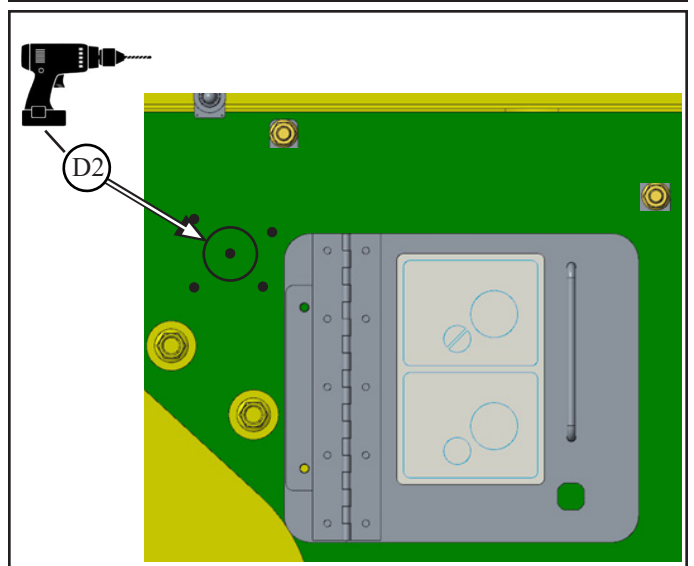

S600 Series

2.2 Remove inspection door (H) from both sides of combine
- to be reinstalled

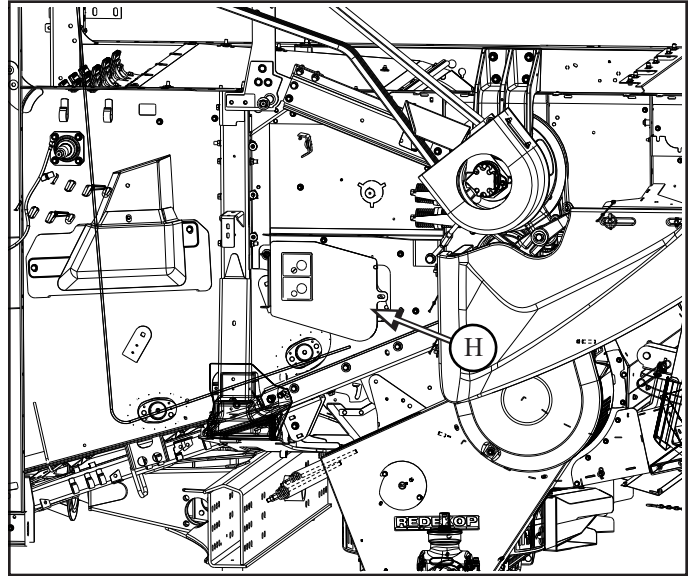

2.2.1 Clamp drill template (E) onto door (H)
- ensure edges of template are flush with edges of door

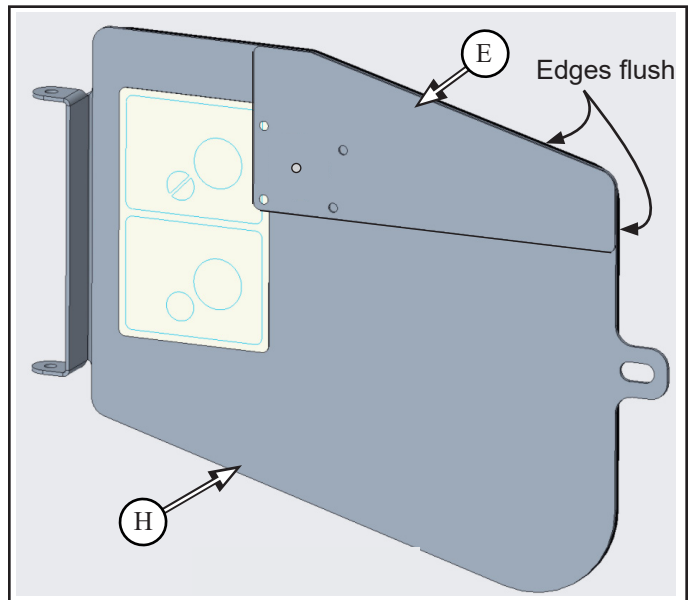

2.2.2 Using template (E), drill 6mm holes (E1) x5 through door (H)

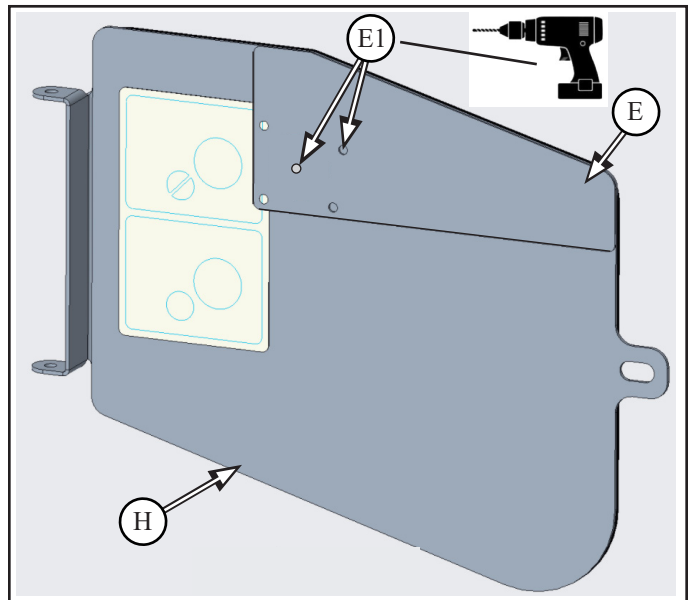

2.2.2.1 Remove template (E)

2.2.3 Drill 41mm hole (**E2**) with supplied hole saw (**F**) using pilot hole through door (**H**)

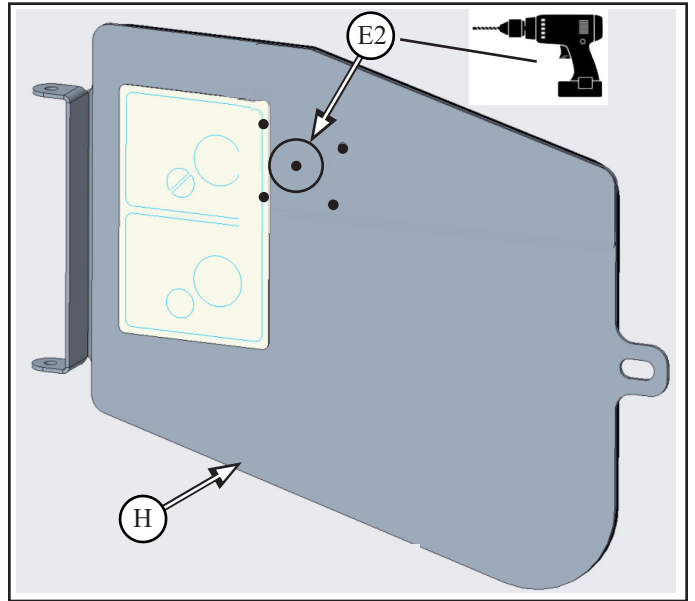

2.3 Re-install chaff divider panel (**B**) with deflector plates (**AL & AR**) to inside of combine

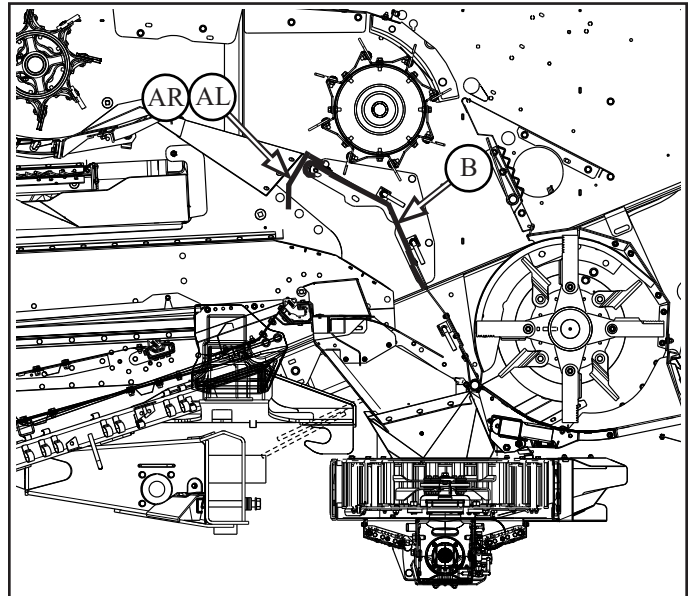

- 2.4** Install optical sensor assemblies (**CL & CR**) into drilled holes (**D1**) on each side of combine, with
- M6 x 12 flange head bolt and flange nut (**C1**) x4
 - ensure head of bolt is on inside of combine and nut is outside
- Receiver on left side
 - Emitter on right side

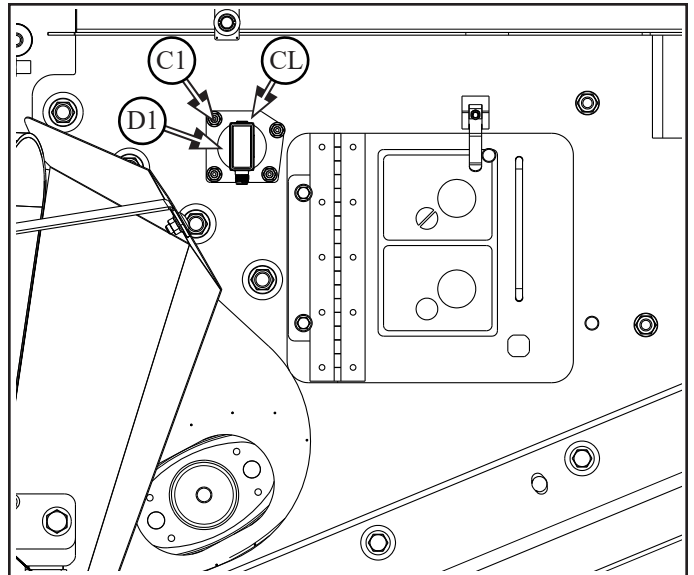

S700 Series

- 2.5** Apply CHAFF Sense decal (**M**) to side of combine near optical sensor (**CL**)
- both sides

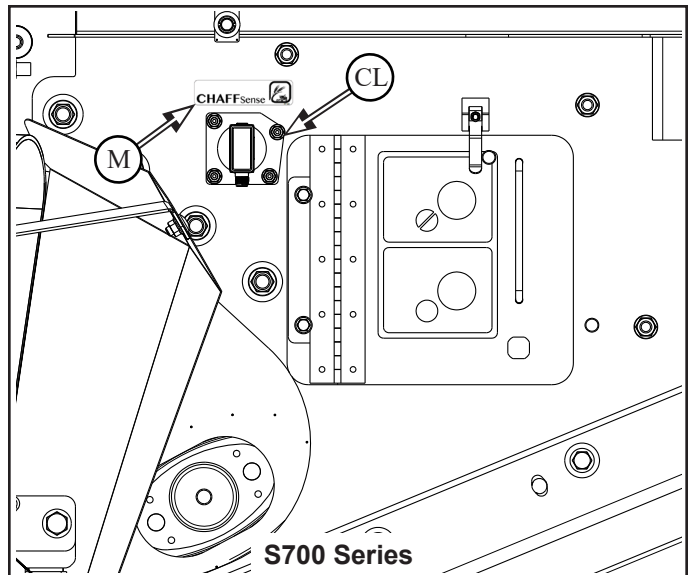

S600 Series

- 2.5.1** Apply CHAFF Sense decal (**M**) to side inspection door near optical sensor (**CL**)
- both sides

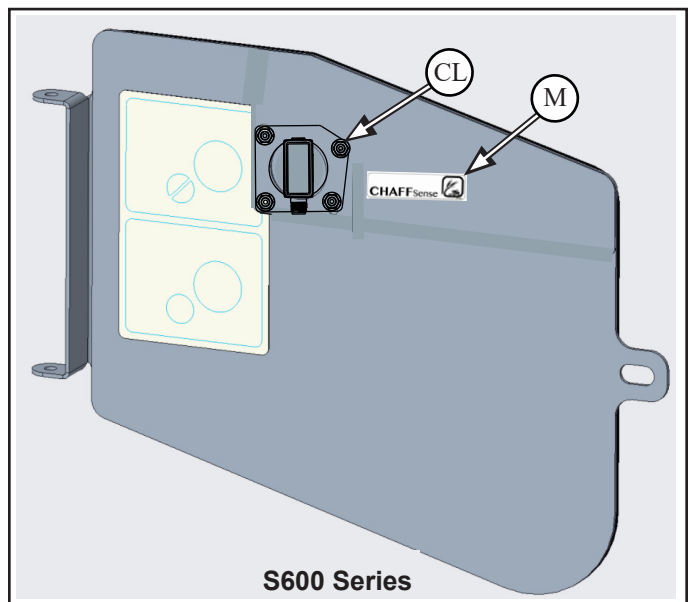

Note: SC664B Blanking Plates (N) have been supplied for future use to cover the blockage sensor holes if the blockage sensors are removed and moved to another machine.

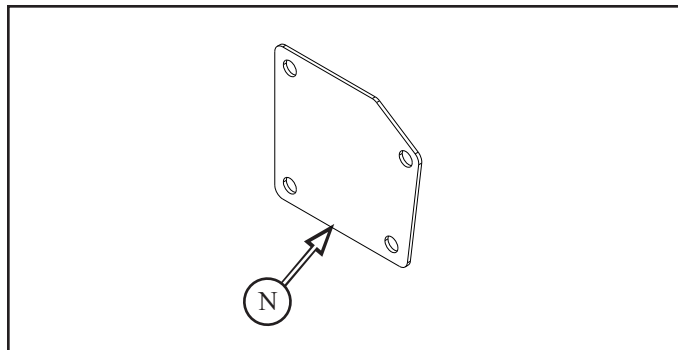

3 Wiring Installation

Parts List:

RP1758A Harness w/Blockage Sensor SCU (J) Qty 1

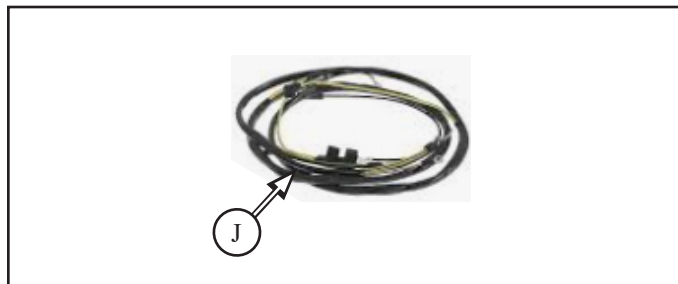

3.1 Install blockage sensor harness (J)

- route along existing battery harness and other harnesses as shown along wall and underneath combine to BLOCKAGE connector near ECU

3.1.1 Connect the EMITTER and RECEIVER plugs on harness (J) to the appropriate optical sensor assemblies (A)

- secure in place

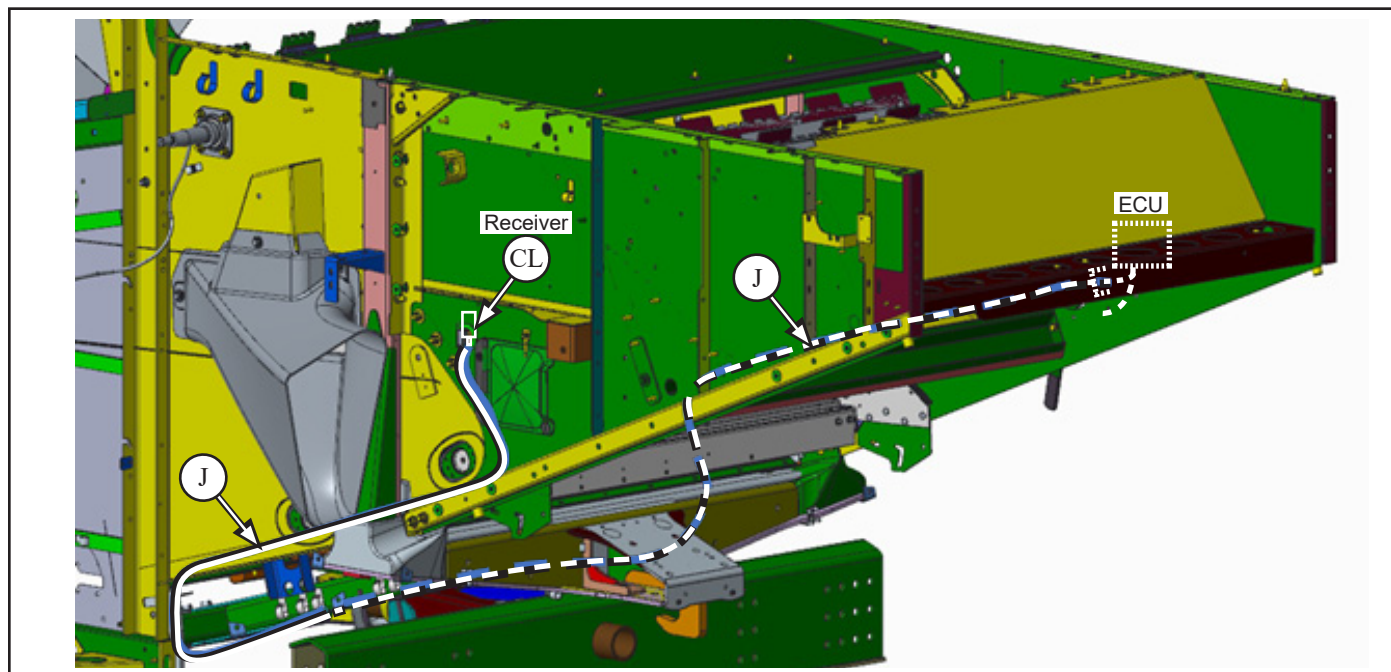

3.1.2 Connect blockage harness (J) to BLOCKAGE connector (K) on pigtail of main harness from ECU

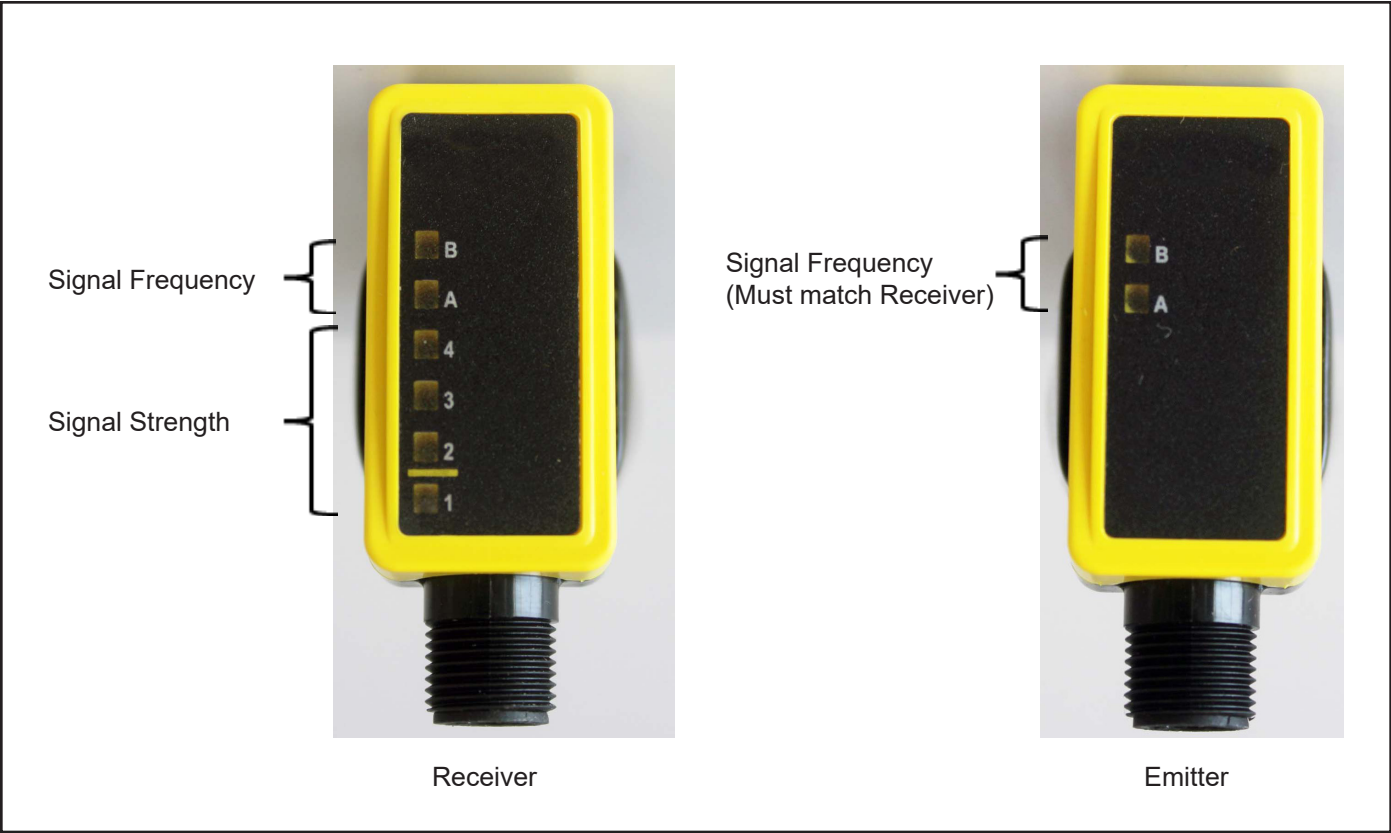
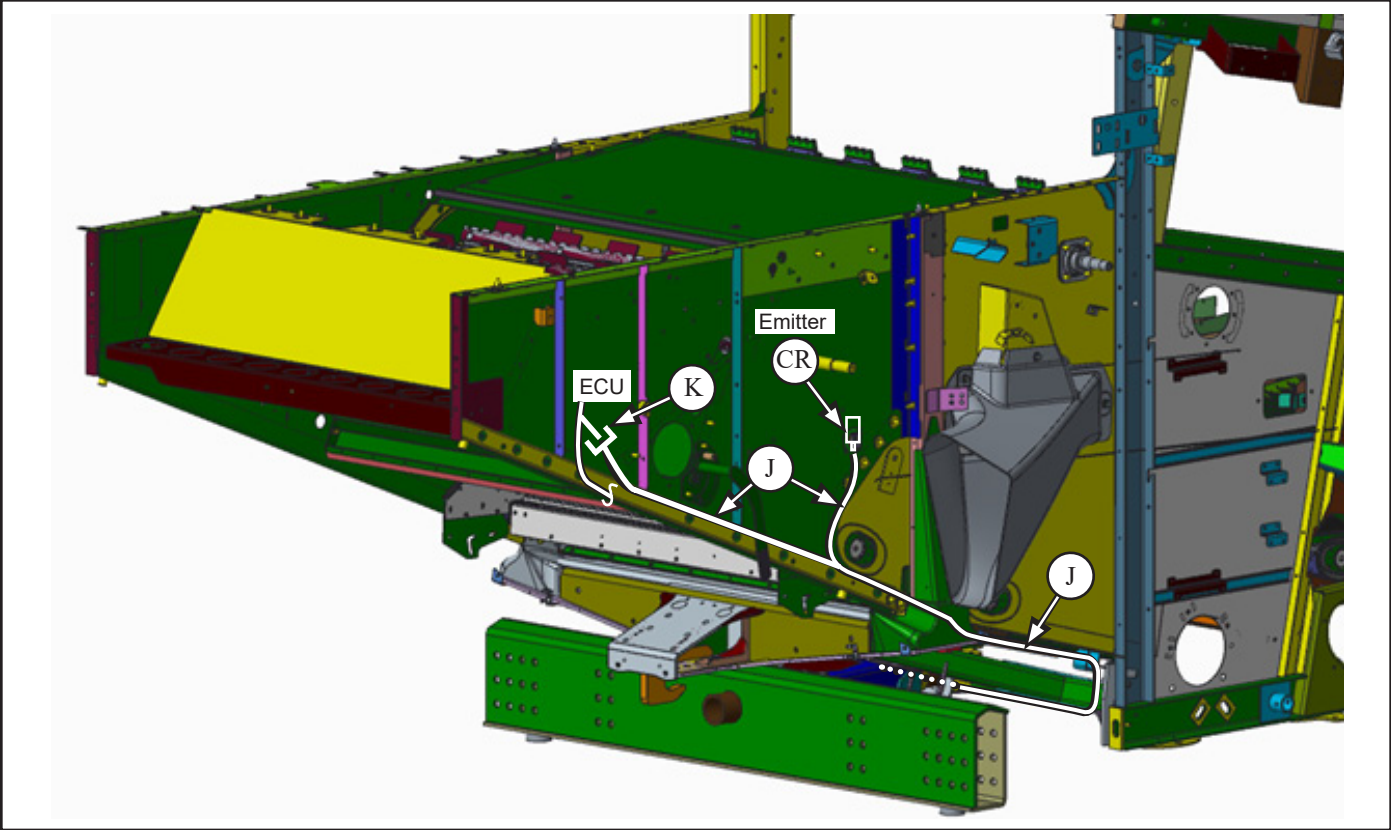

4 Software Settings

IMPORTANT



ECU requires v5 firmware or above
Refer to service tool manual for updating if required

v7+ firmware requires Step 4.1 and 4.2

v5 or v6 firmware only requires step 4.2

4.1 Activate Software code for the Blockage option (labeled Aux Sensor on screen)

To install the appropriate parts of the software, the following codes have to be entered

Select settings **(A)** from main page

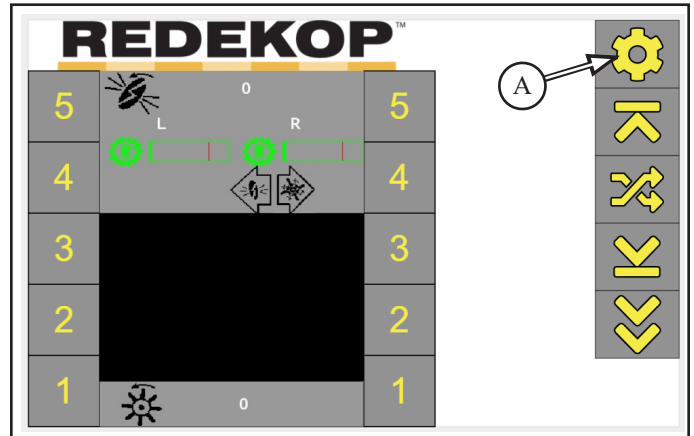

Select "FEATURES" **(B)** page

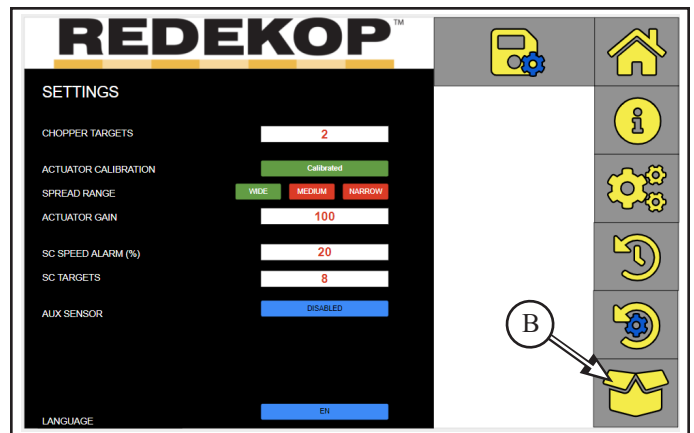

Select "UNINSTALLED" **(C)** beside AUX SENSOR
(Blockage option)

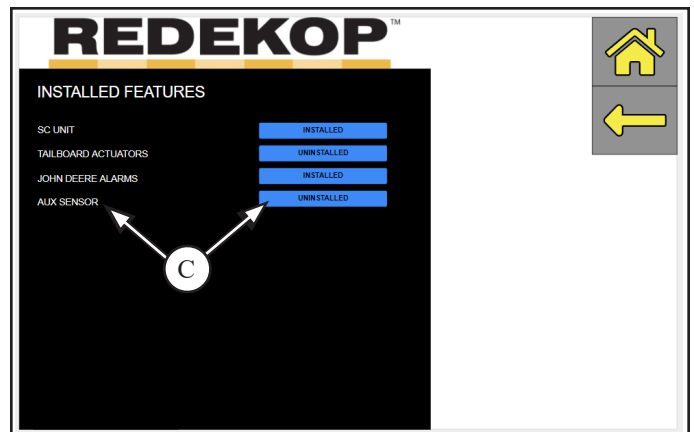

Screen defaults to code input screen displaying 00000

To enter new code, select numbers on sidebar, code will display in center of screen

BLOCKAGE Code: 14394

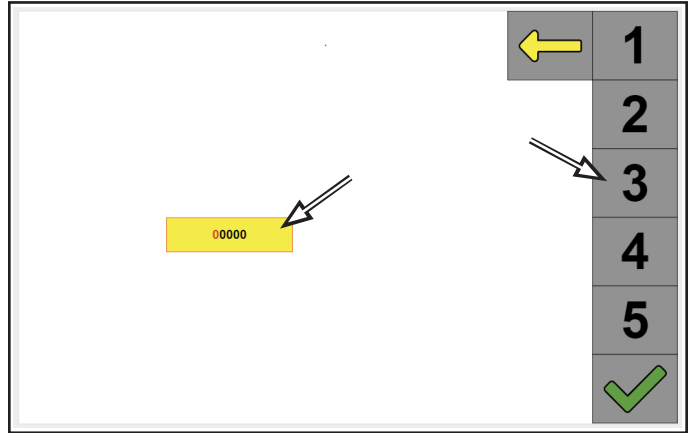

Option now states "Installed"

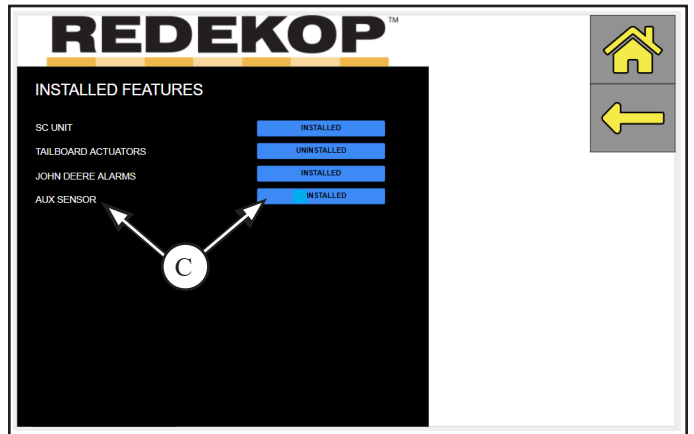

v5 or v6 firmware only requires step 4.2

4.2 The blockage sensor functionality can be enabled / disabled in the settings menu (D). Tapping the button (E) beside BLOCKAGE SENSOR will cycle through either 'Disabled' or a time delay. This delay is the amount of time that the blockage sensor must be covered to trigger an alarm.

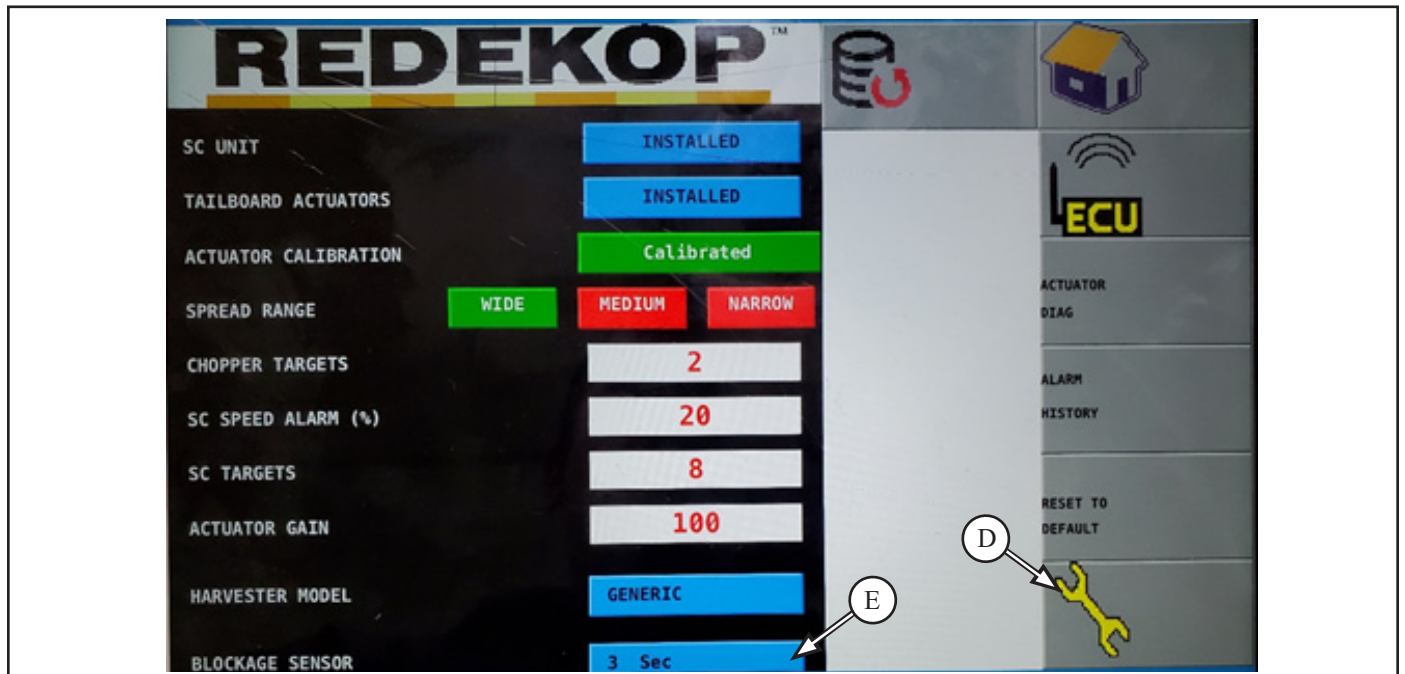

A new “Blockage Detected” icon (**G**) will appear when the blockage sensor detects a blockage. This can be seen below.

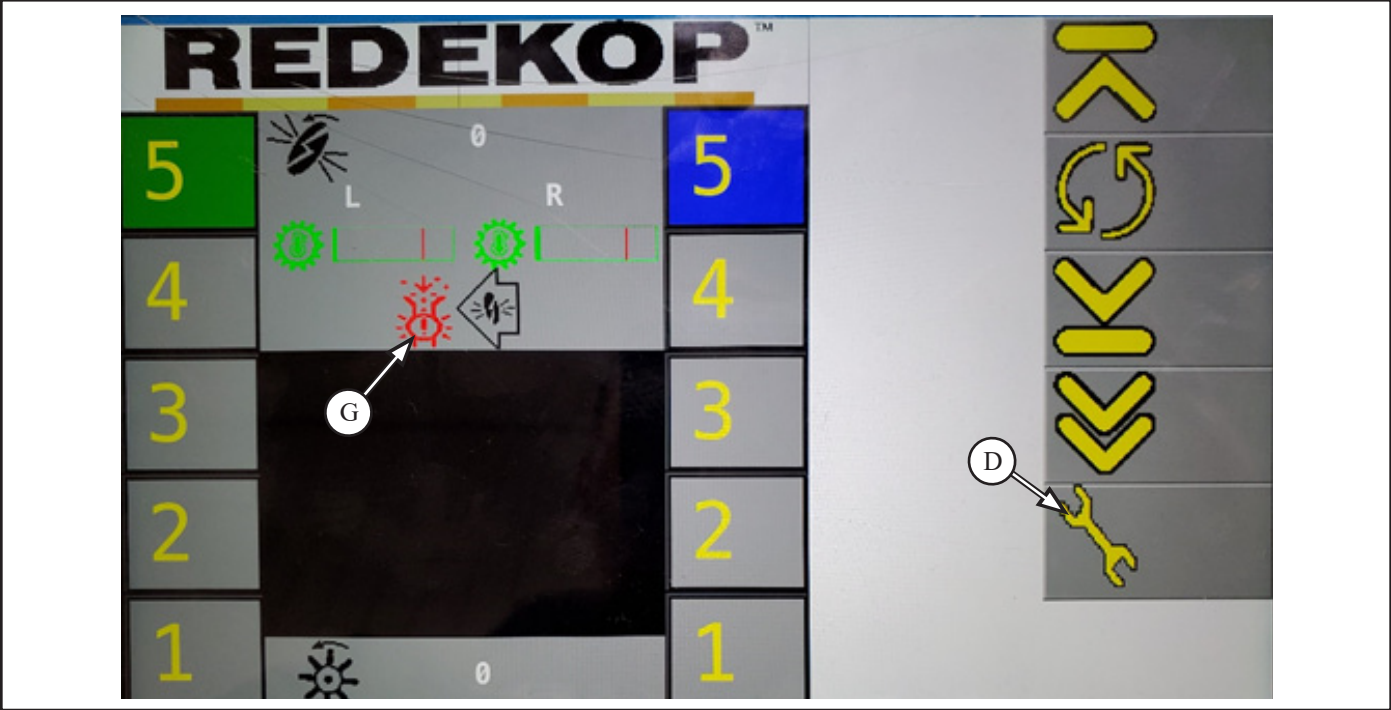



CAUTION

Check that all tools and loose hardware have been removed from the combine and SCU before running SCU



CAUTION

Check all fasteners to ensure they have been properly tightened

Torque Table

Nominal Size	Class 8.8	Class 10.9
	Nm / (ft-lbs)	Nm / (ft-lbs)
M8 - flanged	27 / (20)	39 / (29)
- non flanged	25 / (18)	35 / (26)
M10 - flanged	54 / (40)	57 / (42)
- non flanged	49 / (36)	70 / (51)
M12 - flanged	93 / (69)	134 / (98)
- non flanged	85 / (63)	121 / (90)



CAUTION

Wear Hearing Protection during operation



CAUTION

When starting chopper, be sure all people are clear of the rear of the combine



Start threshing module in low speed and listen for clearance problems. If a knocking noise is heard, stop the machine immediately! Fix problem and repeat procedure. Progress to full power when everything is running smoothly at lower speeds.

REDEKOP MANUFACTURING

1.866.REDEKOP (1.866.733.3567)

Saskatoon, Saskatchewan Canada S7K 3J7

info@redkopmfg.com

www.redkopmfg.com

For additional and the most up to date Manuals:



EQR002

REDEKOP™

REDEKOP™