



Case IH AFX 7120-9120, 7230-9230, 7240-9240 & 9250 Series Removal Guide for Installation of Redekop MAV Straw Chopper

Case IH AFX 120, 230, 240 & 9250 Series Factory Component Removal Guide for Installation of Redekop MAV Straw Chopper

Table of Contents

	<u>Section</u>
Safety	0
Left Rear Side Access Panel	1
Factory Drive and Components	2
Ladder Assembly	3
Straw Spreader Assembly	4
Internal Straw Door	5
Internal Straw Deflector	6
Sieve Extension	7
Hydraulic Oil Level	8

Case IH AFX 120, 230, 240 & 9250 Series Factory Component Removal Guide for Installation of Redekop MAV Straw Chopper

Component Reference

1. Left Rear Access Panel
2. Drive Components
3. Ladder
4. Straw Spreader
5. Internal Straw Door
6. Internal Straw Deflectors
7. Sieve Extension
8. Hydraulic Oil Level



Parts required to be installed during the removal procedure:

CS627S Fitting Kit Contents:

Part # H14-12F Hydraulic Cap 12 FORS Fitting - Qty 2

- found in box CS849S, bag CS840S

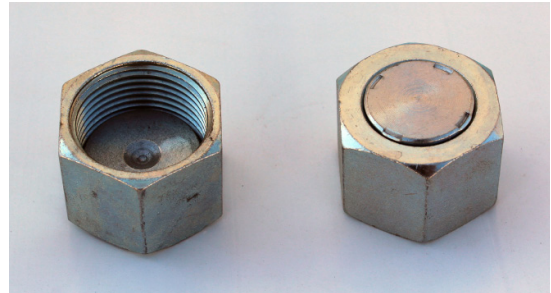

If you are preparing the combine prior to the arrival of the MAV Strawchopper kit, purchase:

Part # 9840575 x2 from CNH Parts

Supplies required to assist during the removal procedure:

Requirements:

Blocking

- 10 x 8 x 43 inches / 250 x 200 x 1100 mm
- required for section 0.13.2



Gear Puller

- required for section 2.4



Locking Mechanism

- required for section 3.2



Clean Pail

- 5 gal / 25 litres of capacity
- required for section 4.1



Pallet

- 40 x 70 inches / 1000 x 1800 mm
- required for section 4.3



0 Safety

0.1 Introduction

0.1.1 IMPORTANT: Read through this instruction thoroughly and familiarize yourself with the machine before removing these components. Do not skip steps or perform them out of order.

This instruction manual explains the proper procedure for preparing the combine and removing the Factory Spreader Components in order to install the Redekop MAV Chopper



0.2 Recognize Safety Information

0.2.1 This is a safety-alert symbol. When you see this symbol on your machine or in this manual, be alert to the potential for personal injury.

Follow recommended precautions and safe operating practices.



0.3 Understand Signal Words

0.3.1 A signal word - DANGER, WARNING, or CAUTION - is used with the safety-alert symbol. DANGER identifies the most serious hazards.

WARNING or CAUTION safety signs are located near specific hazards or precautionary areas in this manual.



0.4 Follow Safety Instructions

0.4.1 Carefully read all safety messages in this manual and on your machine. Keep safety signs in good condition. Replace missing or damaged safety signs. Be sure new equipment components and repair parts include the current safety signs. Replacement safety signs are available from your dealer.

There can be additional safety information contained on parts and components sourced from suppliers that is not reproduced in this operator's manual.

Learn how to operate the machine and how to use controls properly. Do not let anyone operate without instruction.

Keep your machine in proper working condition. Unauthorized modifications to the machine may impair the function and/or safety and affect machine life.

If you do not understand any part of this manual and need assistance, contact your dealer.

Other languages are available for this machine. Please contact Redekop



0.5 Safe Operating Practices

0.5.1 DO NOT stand near combine when machine is running.

ALWAYS refer to your Combine Operator's Manual, and review the Safety section before operating machine. The Combine Operator's Manual details safe operating practices that must be followed to protect you and others from accidental death and/or injury.

Operate machine only when all guards are correctly installed.

Before moving away, always check immediate vicinity of machine (e.g. for children). Ensure adequate visibility. Use the horn as a warning immediately before moving away.

When making turns, always take into consideration the width of the attachment and the fact that the rear end of the machine swings out. Attachments and ground conditions affect the driving characteristics of the combine.

Never leave machine unattended as long as engine is running.

0.6 Work In Ventilated Area

0.6.1 Engine exhaust fumes can cause sickness or death. If it is necessary to run an engine in an enclosed area, remove the exhaust fumes from the area with an exhaust pipe extension.

If you do not have an exhaust pipe extension, open the doors and get outside air into the area.

0.7 Practice Safe Maintenance

0.7.1 Understand service procedure before doing work. Keep area clean and dry.

Never lubricate, service, or adjust machine while it is moving. Keep hands, feet, and clothing from power-driven parts. Disengage all power and operate controls to relieve pressure. Lower equipment to the ground. Stop the engine. Remove the key. Allow machine to cool.

Securely support any machine elements that must be raised for service work.

Keep all parts in good condition and properly installed. Fix damage immediately. Replace worn or broken parts. Remove any buildup of grease, oil, or debris.

On self-propelled equipment, disconnect battery ground cable (-) before making adjustments on electrical systems or welding on machine.



0.8 Avoid Contact With Moving Parts

0.8.1 Keep hands, feet and clothing away from power driven parts. Never clean, lubricate or adjust machine when it is running.



0.9 Avoid High-Pressure Fluids

0.9.1 Escaping fluid under pressure can penetrate the skin causing serious injury.

Avoid the hazard by relieving pressure before disconnecting hydraulic or other lines. Tighten all connections before applying pressure.

Search for leaks with a piece of cardboard. Protect hands and body from high-pressure fluids.

If an accident occurs, see a doctor immediately. Any fluid injected into the skin must be surgically removed within a few hours or gangrene may result. Doctors unfamiliar with this type of injury should reference a knowledgeable medical source.



0.10 Dispose of Waste Properly

0.10.1 Improperly disposing of waste can threaten the environment and ecology. Potentially harmful waste includes such items as oil, fuel, coolant, brake fluid, filters, and batteries.

Use leakproof containers when draining fluids. Do not use food or beverage containers that may mislead someone into drinking from them.

Do not pour waste onto the ground, down a drain, or into any water source.

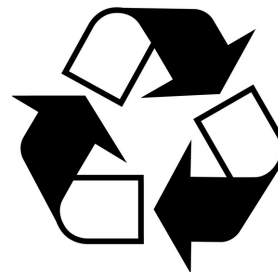

0.11 Use Proper Lifting Equipment

0.11.1 Lifting heavy components incorrectly can cause severe injury or machine damage.

Follow recommended procedure for removal and installation of components in the manual.

Ensure lifting equipment is rated for the job

Ensure operator is appropriately licensed to operate lifting equipment



0.12 Personal Protective Equipment (PPE)

0.12.1 A Qualified Person designated by the employer, who is knowledgeable about and familiar with all relevant specifications and assembly instructions and is capable of identifying existing or potential hazards in surroundings or working conditions which may be hazardous or dangerous to employees shall determine appropriate Personal Protective Equipment required for this assembly.



Personal Protective Equipment (PPE) are devices worn by the employees to protect against hazards in the environment. Examples include safety glasses, face shields, respirators, gloves, hard hats, steel-toe shoes, and hearing protection.

0.13 Master Power

0.13.1 Shut off engine, remove keys (A) from the combine cab

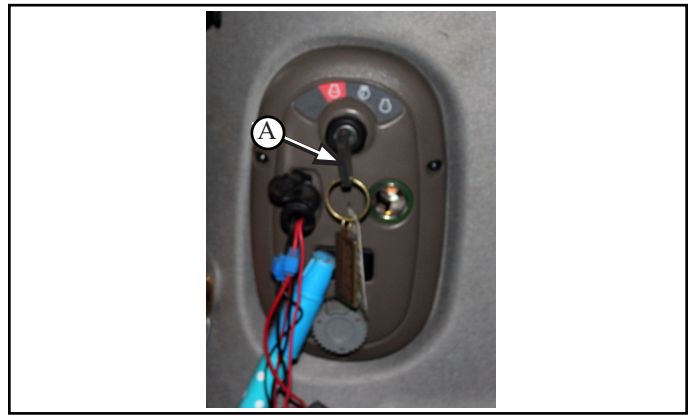

0.13.2 Block (B) wheels on level ground



0.13.3 Lift up the left rear side access panel (C)

0.13.4 Turn Master Power Off (D)



1 Left Rear Side Access Panel Removal (Optional for easier access)

1.1 Left Rear Side Access Panel Removal

1.1.1 Disconnect wire harness (A1) from light

1.1.2 Remove hardware (A2) x2 mounting the left rear side access panel (A) to the combine upper brackets

1.1.3 Remove head of gas springs (A3) x 2 from ball studs on inner mount bracket

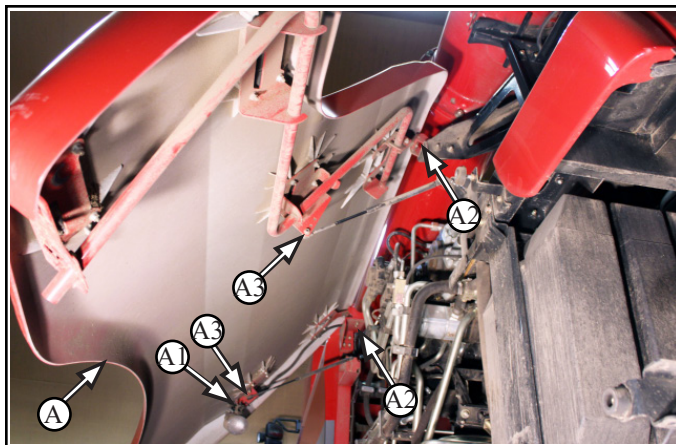

1.1.4 Remove and lower left rear access panel (A) carefully



1.1.4.1 View with panel removed

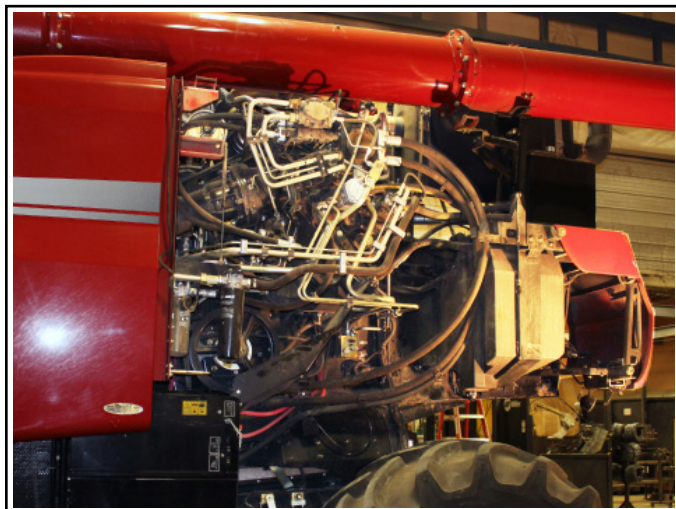

2 Factory Drive and Component Removal

2.1 Outer Belt Removal

2.1.1 Loosen Tensioner Rods (A) x2

2.1.2 Remove outer belt (B) CNH #86517680

- not to be reused

2.2 Inner Belt Removal from drive pulley

2.2.1 Remove inner belt (C) from drive pulley (D)
- leave loose, do not remove from combine

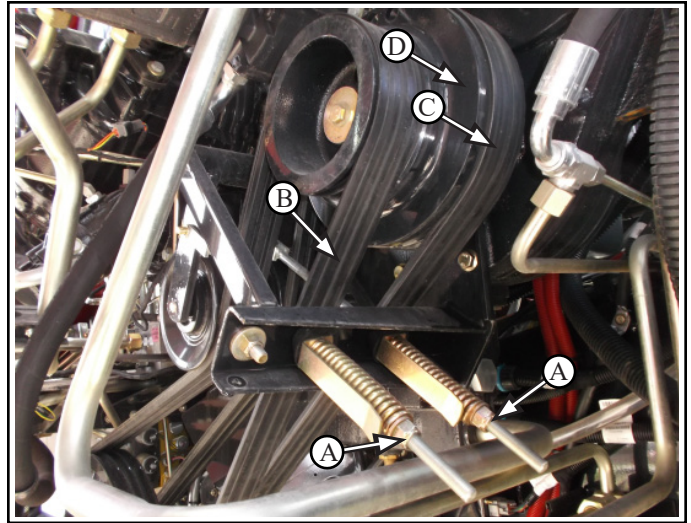

2.3 Drive Pulley Removal

2.3.1 Remove center bolt (D1) from drive pulley (D)

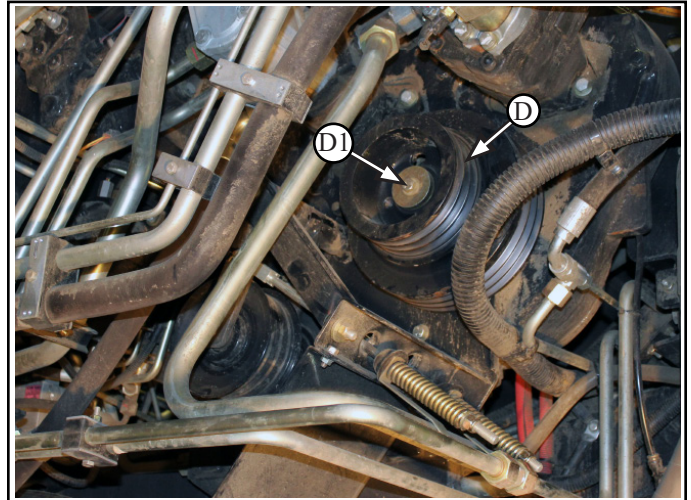

2.3.2 Remove upper drive pulley (D) using a gear puller (D2)

- not to be reused

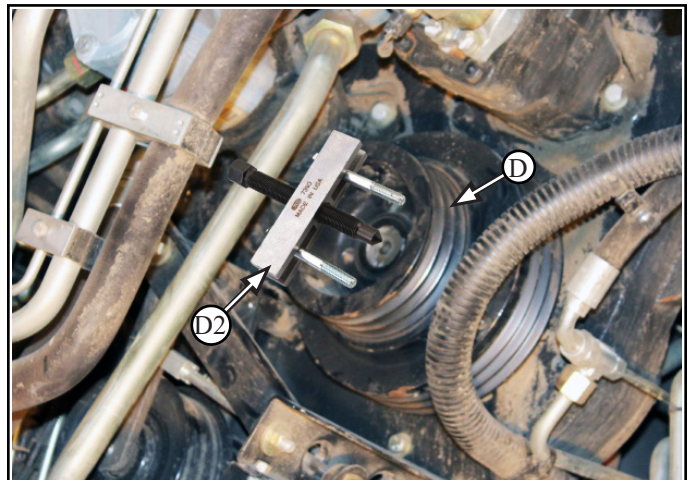

2.3.3 Replace center bolt and washer (**D1**) onto shaft (**D3**)

2.3.4 Ensure key (**D4**) remains in shaft (**D3**)
- secure key in place with tape if required

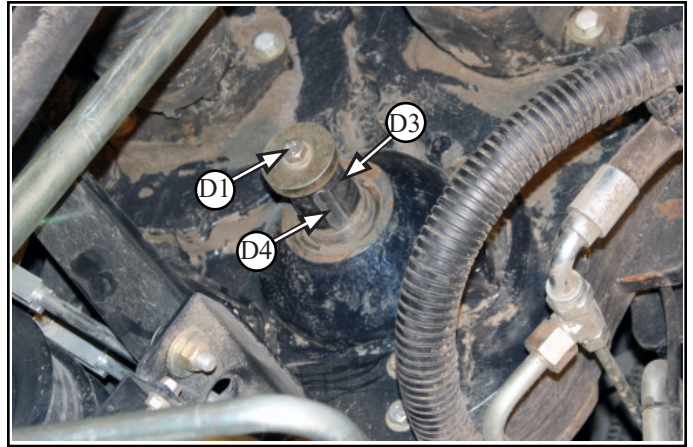

3 Ladder Components Removal

Reference:

- A - Glamour Panel
- B - Gas Springs
- C - Pivot Tube
- D - Roller Guides
- E - Ladder

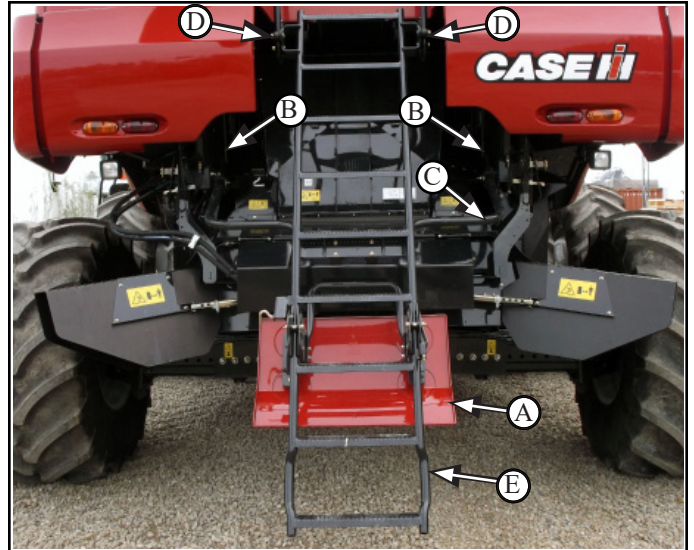

3.1 Glamour Panel Assembly Removal

3.1.1 Unfold Ladder (E)

3.1.2 Remove hardware (A1) x4 mounting the glamour panel assembly (A) to the back of ladder mounting plates (E1)

- Do Not scratch the glamour panel (A) - place on or cover with a protective wrap

- Glamour panel to be reinstalled with the MAV straw chopper ladder

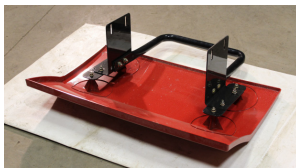
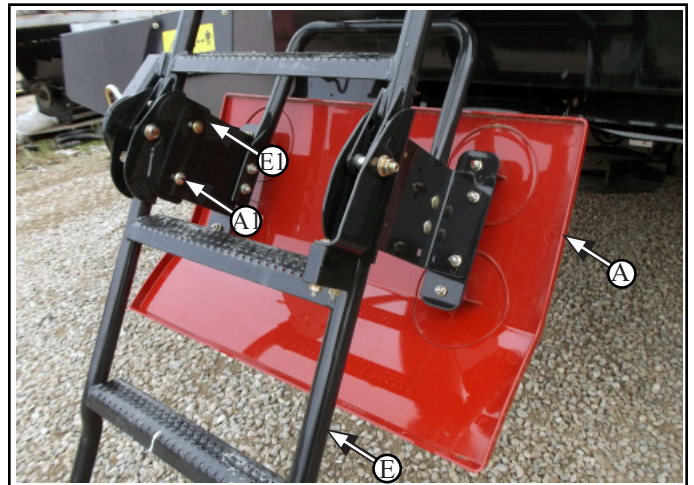

3.1.3 Ladder Handle Assembly Removal from Glamour Panel

3.1.4 Remove hardware (A2) x4 mounting the ladder handle assembly (E2) onto the glamour panel (A)

- Do Not Scratch the glamour panel (A)

- Place on or cover with a protective wrap

- Ladder handle assembly (E2) not to be reused

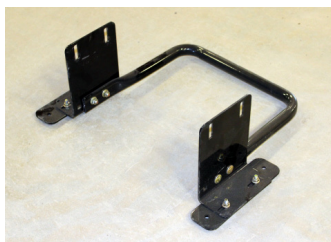
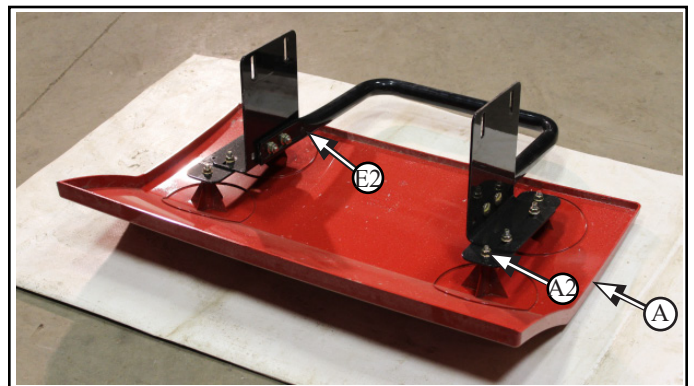

3.2 Gas Spring Removal



3.2.1 To assist in removing gas spring (B), you will need a locking mechanism (F) to hold gas spring in place, for it is under load

3.2.1.1 Apply locking mechanism (F) around gas spring (B) and tighten to hold gas spring in place

3.2.1.2 Remove clip (B1) from top end of gas spring (B)

3.2.2 Unbolt lower gas spring head (B2) from ladder pivot tube plate (C1)

3.2.2.1 Hold gas spring (B) and angle out until the top end releases from the ball stud (B3)

3.2.3 Remove locking mechanism (F) from around gas spring (B) when it has been removed.



****CAUTION**** gas spring (B) will extend

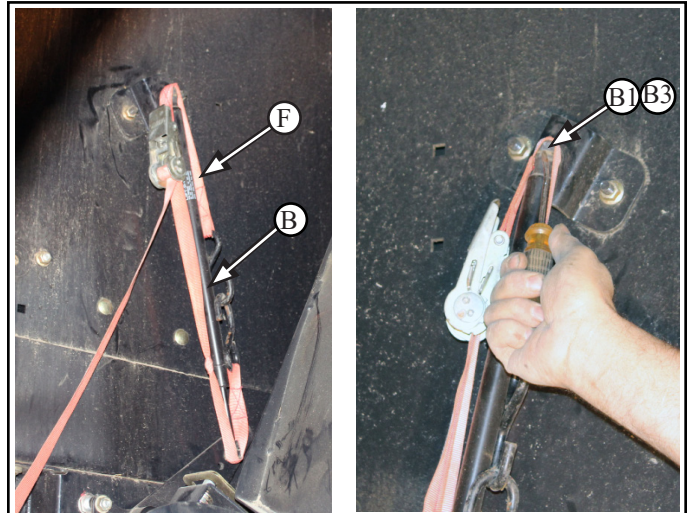

3.2.4 Repeat for the other side

- one (1) to be reinstalled on ladder support
- one (1) not to be reused

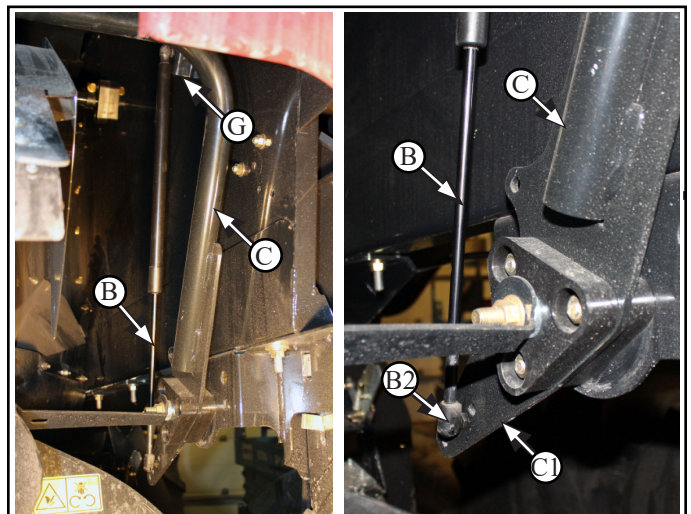

3.2.5 Remove mounting hardware (**G1**) x 2 attaching the gas spring mount brackets (**G**) x2 to the upper inside combine walls - both sides

- ensure bolts do not fall out of sidewall
- place nuts back on bolts

- not to be reused

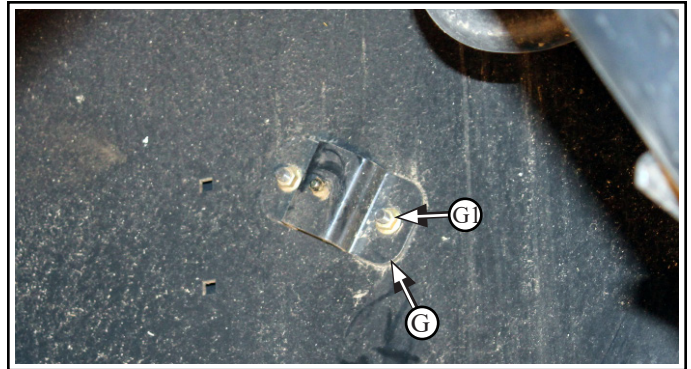

3.3 Ladder Removal

3.3.1 Remove hardware (**H1**) x4 from the back side of the ladder (**E**) mounting the nylon blocks (**H**) x2 around the pivot tube (**C**)

- to be reinstalled on new pivot frame

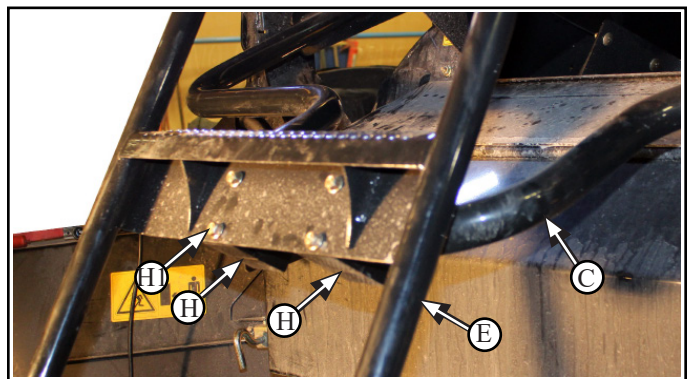

- reassemble hardware onto blocks

3.3.2 Manually support the ladder and twist the top end out of the railing.

- to be reinstalled with the MAV Chopper



3.4 Pivot Tube Removal

3.4.1 Remove Ladder Pivot Tube (C) from inside of the combine mount plate

3.4.2 Remove center bolt (J) mounting the pivot tube plate (C1) to the combine mount plate (C2) - both sides
- Pivot Tube (C) will now slide out

- not to be reused

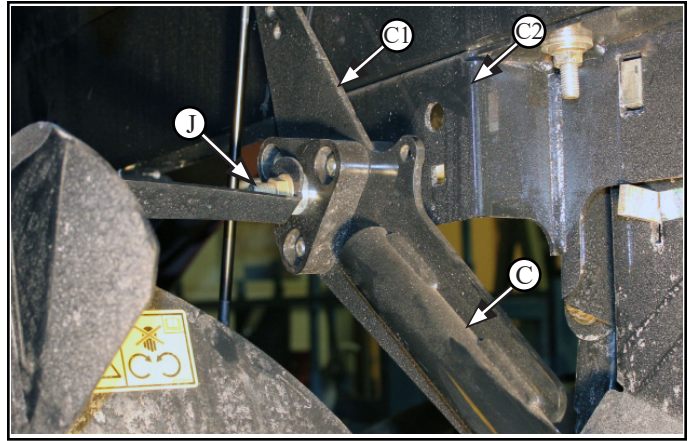

3.4.3 Remove hardware (K1) x3 attaching the pivot tube blocks (K) to the pivot tube (C) - both sides

- to be reinstalled on new pivot frame



- reassemble hardware onto blocks

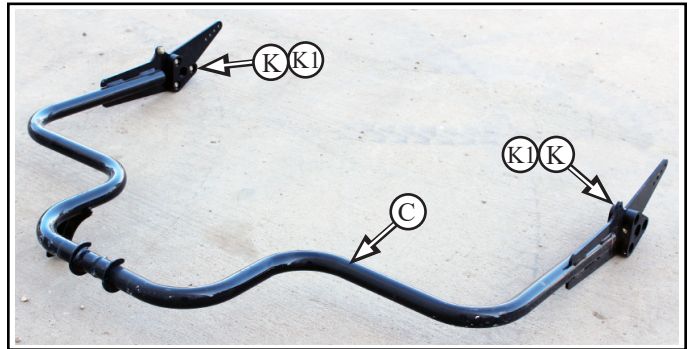

4 Straw Spreader Removal



WARNING

HYDRAULIC LINES MAY BE UNDER PRESSURE

Escaping fluid under pressure can penetrate the skin causing serious injury.

Avoid the hazard by relieving pressure before disconnecting hydraulic or other lines.

Tighten all connections before applying pressure.

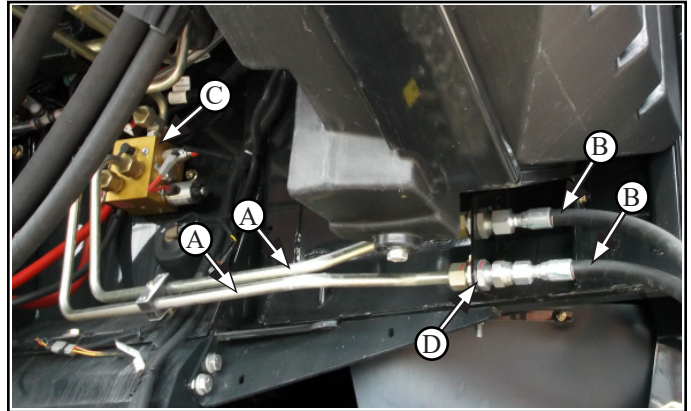

4.1 Hydraulic Hoses Disconnect

4.1.1 Remove steel hydraulic line (A) x2 from hydraulic block (C)

- hoses will leak upon removal, place a pail below to catch any fluids

4.1.2 Hold steel lines up to prevent oil from leaking

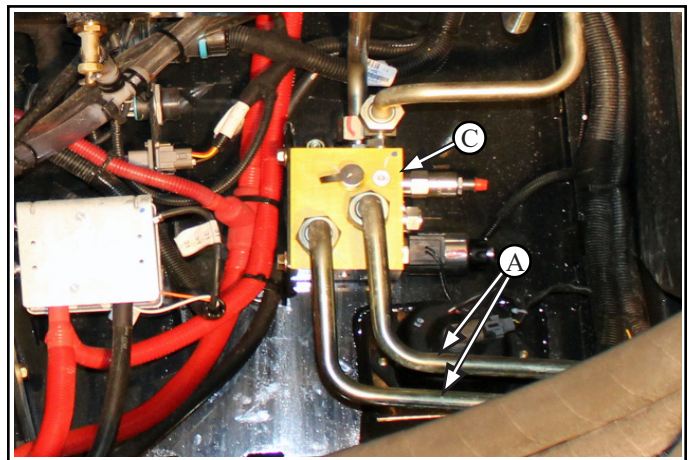

4.1.3 Install Hydraulic Port Caps H14-12F (E) onto ports of hydraulic block (C) where the steel hydraulic lines (A) were just removed from

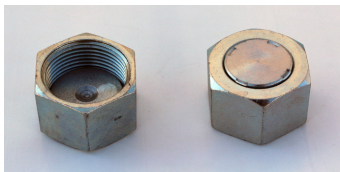

- if removing prior to kit arrival - purchase these 2 fittings in order to drive combine
(CNH Part # 9840575)

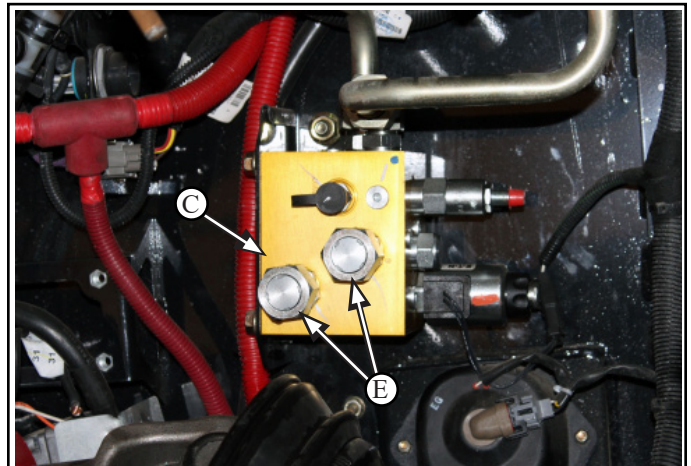



CAUTION

Ensure that the Hydraulic Cap Fittings have been tightened

4.1.4 Remove rubber hydraulic hoses (B) x2 from bulkhead plate (C) below DEF tank
 - hoses will leak upon removal, place a pail below to catch any fluids

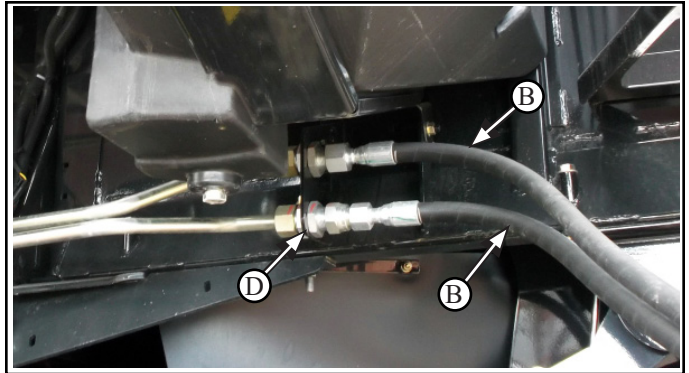

4.1.4.1 Hoses will leak upon removal, place a pail (B1) below to catch any fluids

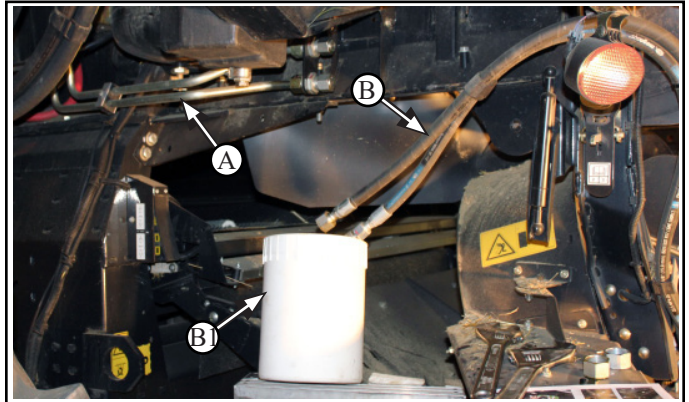

4.1.5 Remove steel hydraulic lines (A) x2 from the bulkhead plate (D)

- not to be reused

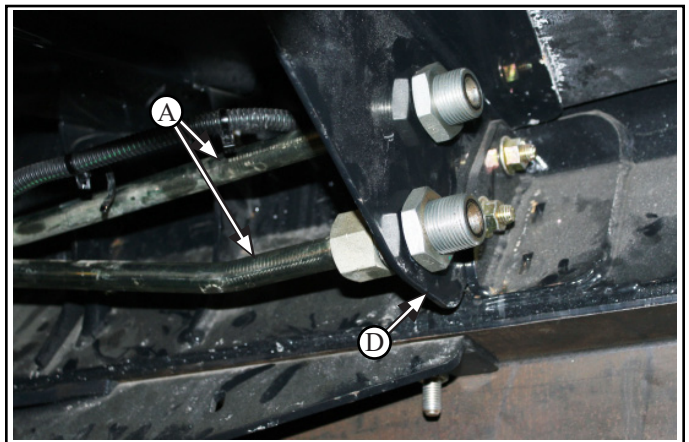

4.1.6 Remove fitting (A1) from one (1) of the steel hydraulic lines (A) just removed

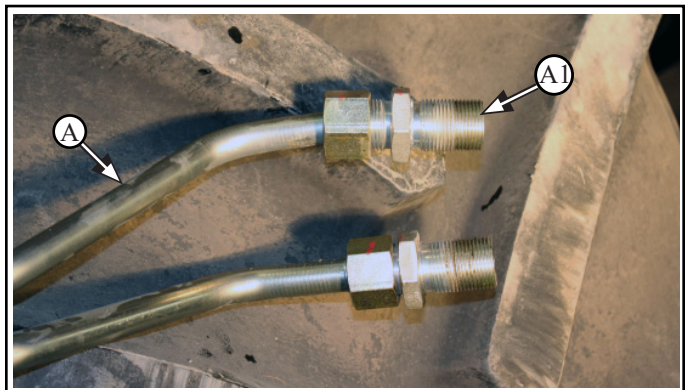

4.1.7 Thread in fitting (A1) into both rubber hydraulic lines (B) to connect together

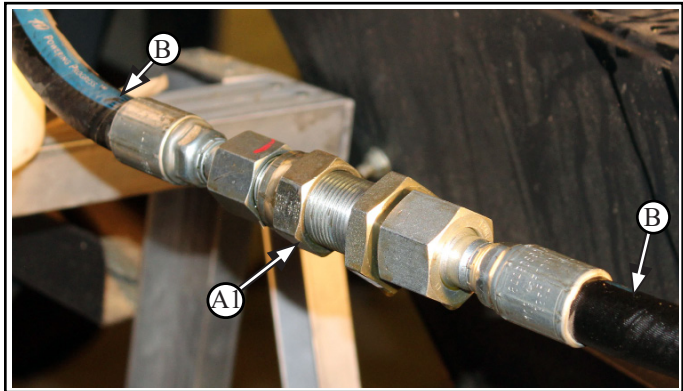
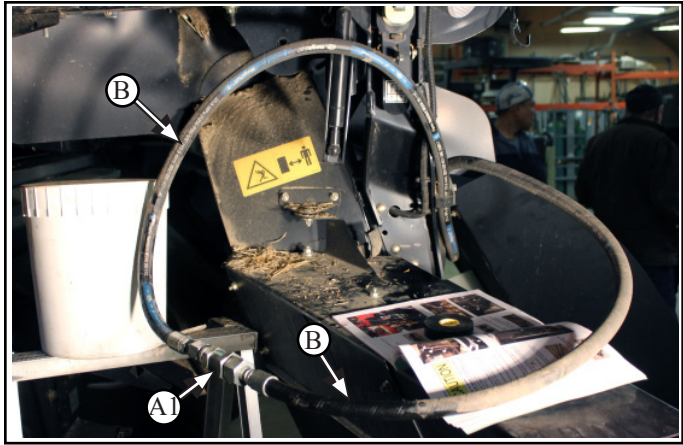

4.2 Disconnect Electrical Harness from Spreader

4.2.1 Disconnect spreader electrical harness connectors (E1) x3 from combine harness at locations noted:

- along spreader
- at proximity sensors x2

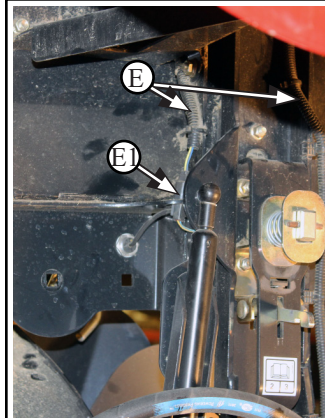
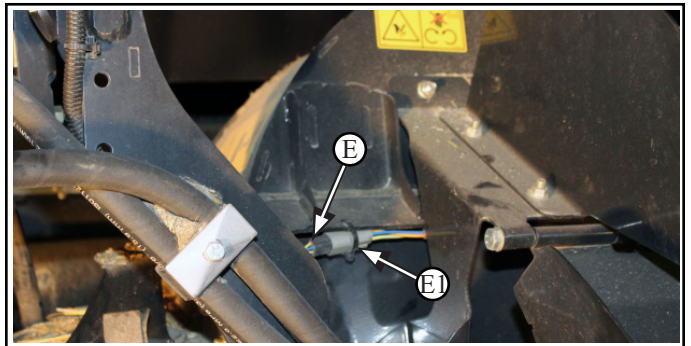
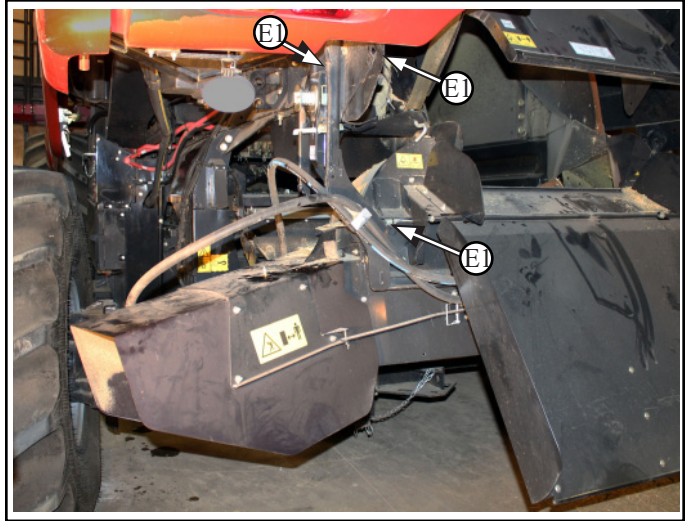

4.2.2 Cut off nylon ties (E2) along Harness (E) to connectors (E1)

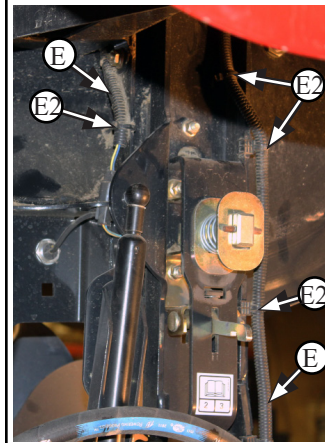

4.2.3 Remove Proximity Sensors (**F1** & **F2**) from upper side plate

- Sensor (**F2**) to be reused for future ladder sensor
- Sensor (**F1**) to be reused on the future Straw Door

4.2.3.1 Label sensors for future identification

- reconnect sensors F2 and F1 to wiring harness if disconnected when removed

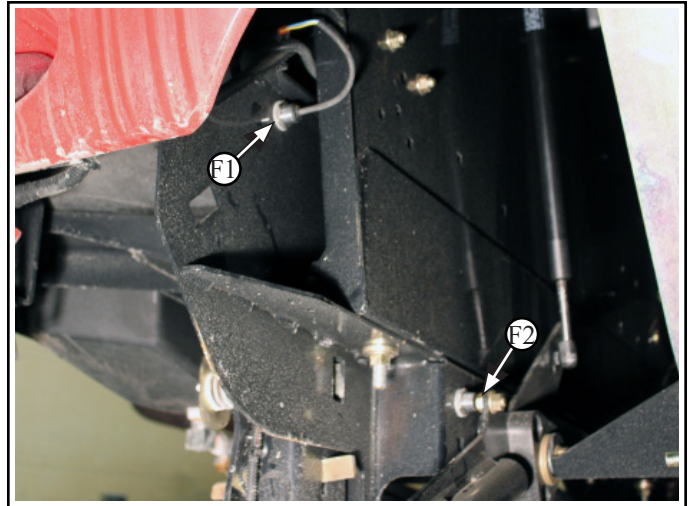

4.2.4 Bundle and tie up the Harness (**E**) and Sensors (**F1** & **F2**) to keep out of the way

- to be reinstalled

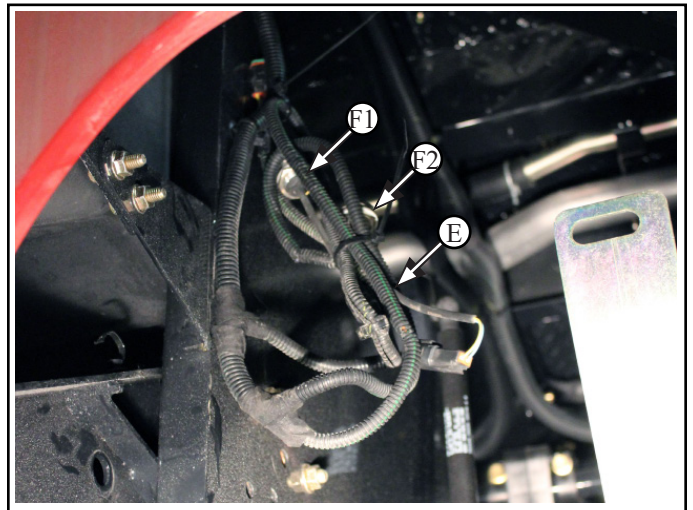

4.3 Straw Spreader Removal



4.3.1 Move deflectors (G1) inwards

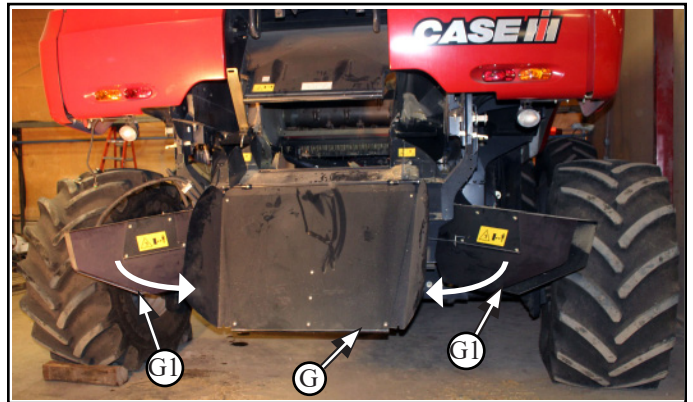

4.3.1.1 Lock deflectors (G1) in place with pin (G2) - both sides

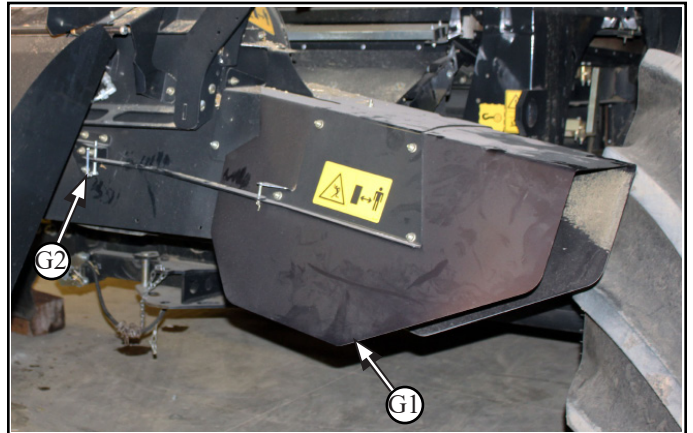

4.3.2 Rotate spreader assembly (G) up into factory raised position

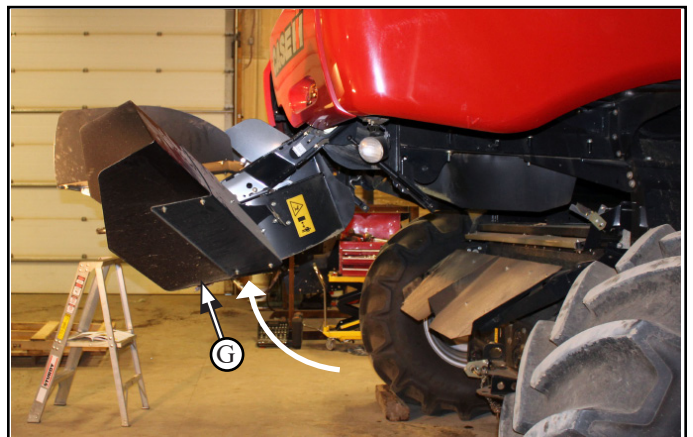

4.3.3 Raise a pallet (H) with extra blocking (H1) underneath the spreader (G) to hold the spreader in place when all supports are removed

4.3.3.1 Secure blocking and spreader onto the pallet



4.3.4 Remove hydraulic hose clamp (G3) from top left spreader mounting arm (G4)

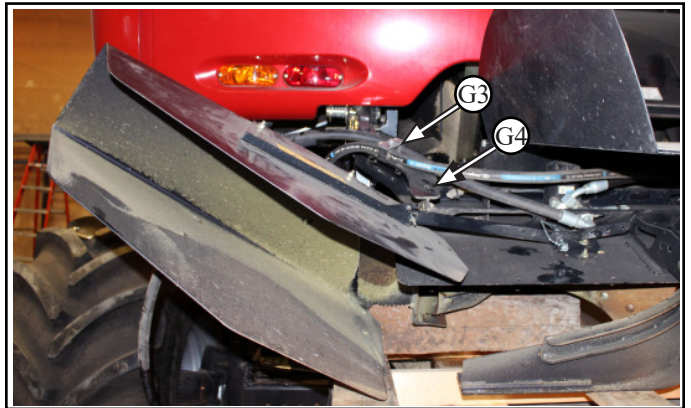

4.3.5 Remove hardware (G5) mounting spreader mounting arms (G4) to spreader (G) - both sides

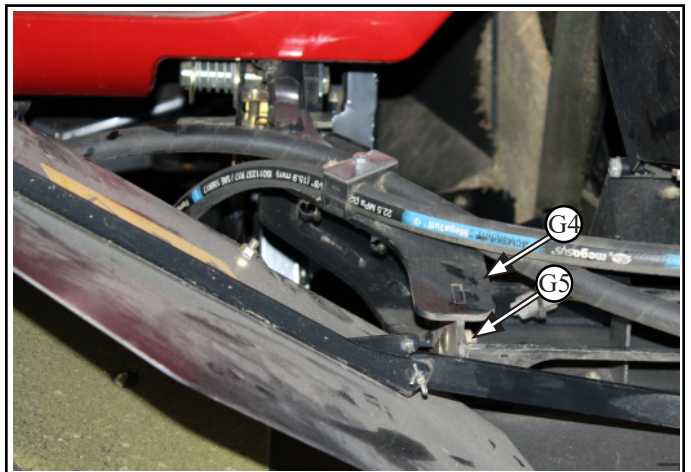

4.3.6 Lower spreader (G)
- not to be reused

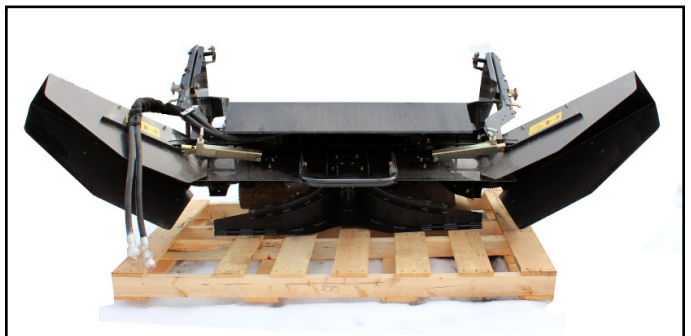

4.3.7 Remove hardware (G6) mounting the spreader arms (G4) to the combine rails (H) - both sides

- not to be reused

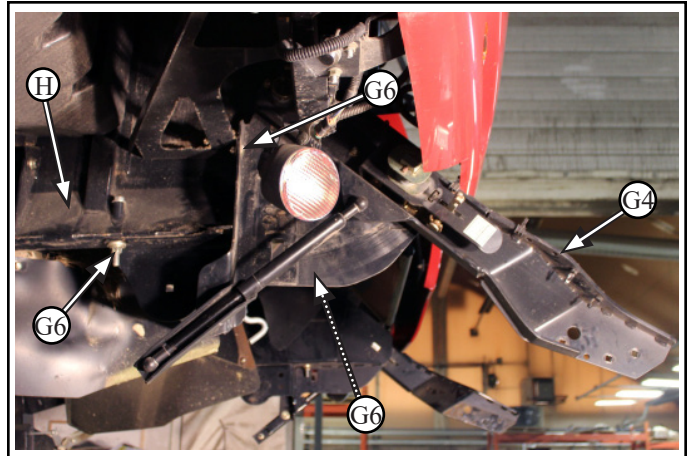

4.3.8 Remove speed sensor (J) from left side hydraulic motor (K) on the spreader assembly (G)

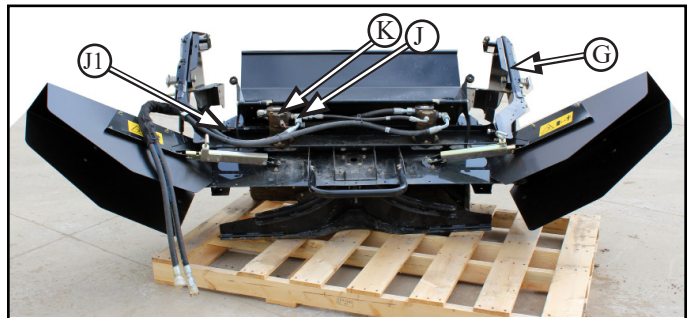

4.3.8.1 Cut off nylon ties (L) securing the speed sensor wire harness (J1) to the spreader assembly (G)

- to be reinstalled in a different location for the MAV straw chopper

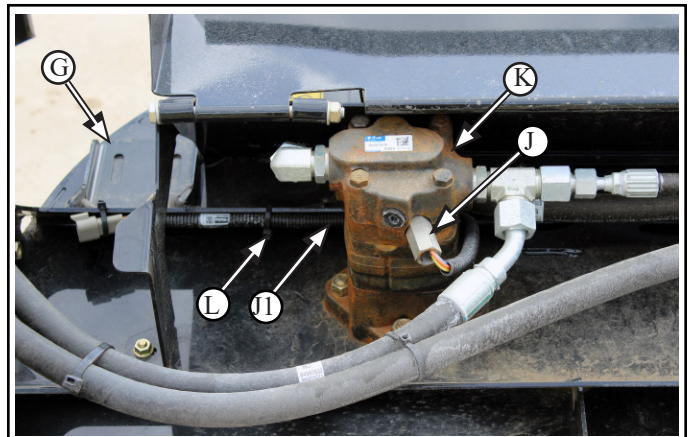

4.3.9 Actuator Removal - if equipped

4.3.9.1 Remove large acutators (M) x2 from spreader assembly

- to be reinstalled on MAV straw chopper

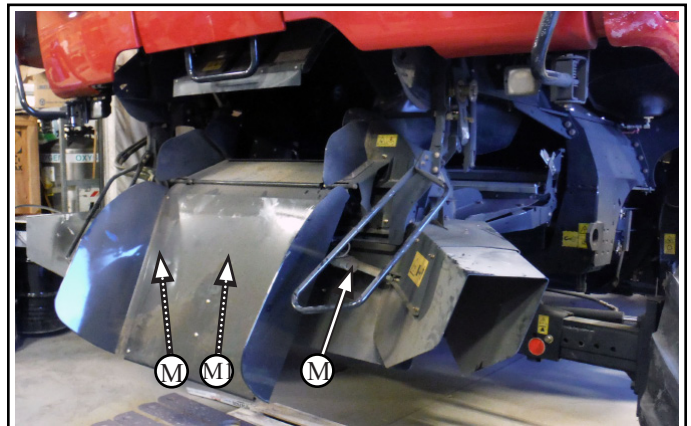

5 Internal Straw Door Removal



5.1 Gas Spring Removal

- 5.1.1** Remove head of gas spring (A1) from internal deflector (C)
- keep base (A2) of gas spring (A) attached to internal door (B)

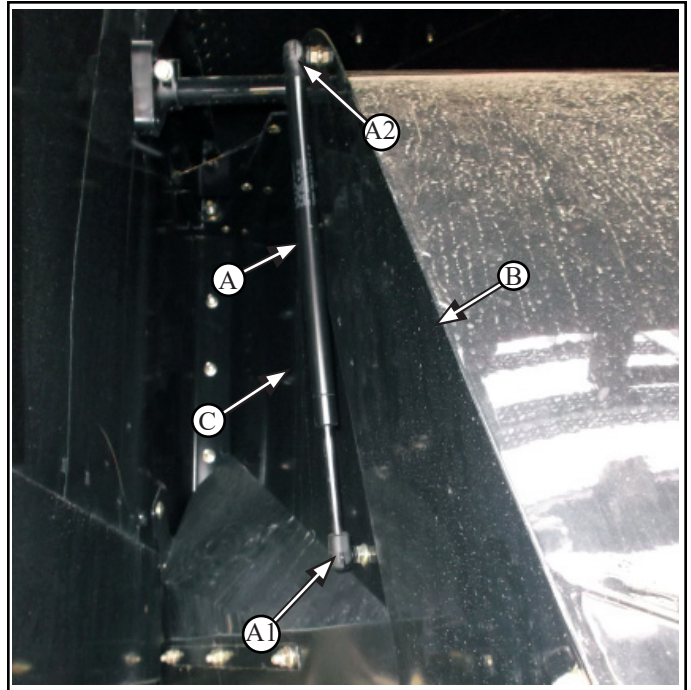

5.2 Internal Straw Door Removal

- 5.2.1** Disconnect actuator (G) from internal door (B) and save pins
- leave attached to combine

- 5.2.2** Loosen lock collars (D) on Internal straw door pivot tube (B1) - both sides

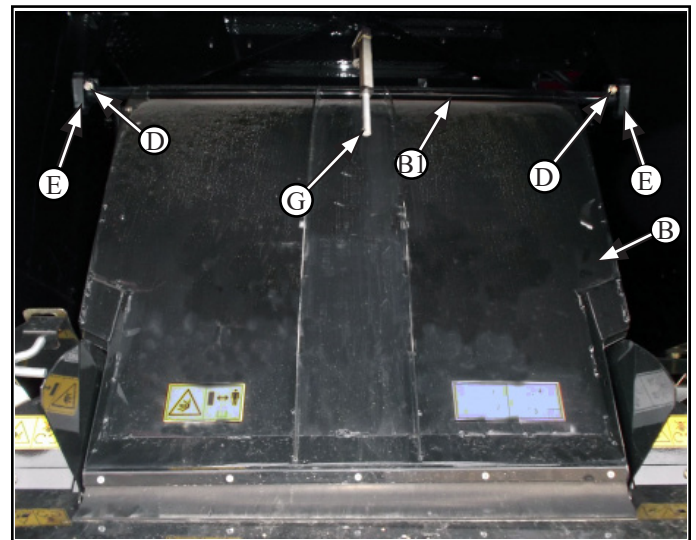

- 5.2.3** Remove hardware (E1) x3 attaching the pivot tube blocks (E) to the combine internal side wall (F) - both sides

- 5.2.4** Pry pivot tube blocks (E) off of welded studs (E2)
- blocks to be reinstalled for new straw door



- 5.2.5** Slide door out
- not to be reused

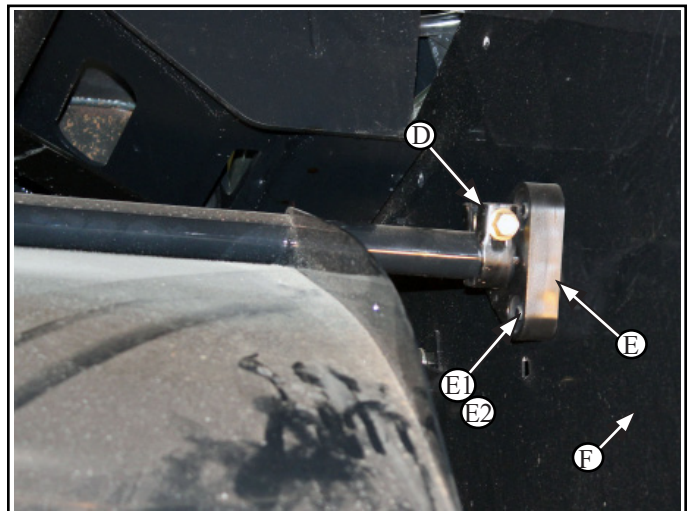

6 Internal Straw Deflector Removal

Reference:

A - Internal Straw Deflectors

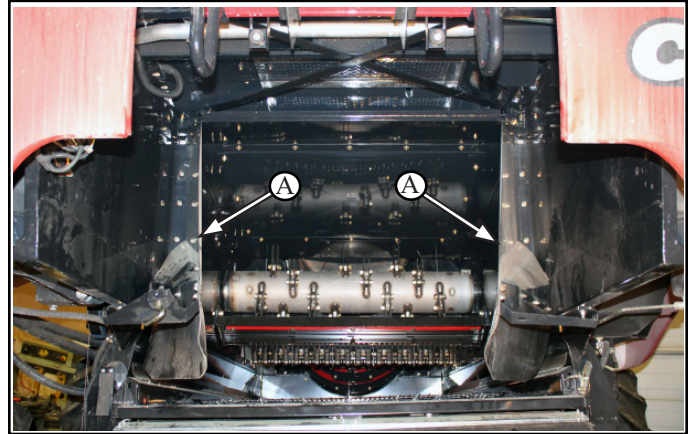

6.1 Internal Straw Deflectors Removal

6.1.1 Remove mount hardware (A1) from lower support bracket (B) attached to combine wall flange (if equipped)

6.1.2 Remove hardware (A2) from lower deflector mounting tab attached to combine side wall

6.1.3 Remove hardware (A3) x3 attaching side deflector to top deflector plate (C)
- Top Deflector Plate (C) stays in place

6.1.4 **LOOSEN** nut (A4) from deflector upper tab mounted to combine tube
- careful not to remove the nut, for the bolt will fall into the tube

6.1.5 Slide the Internal Side Deflector off the bolt (A4)
- both sides

- not to be reused

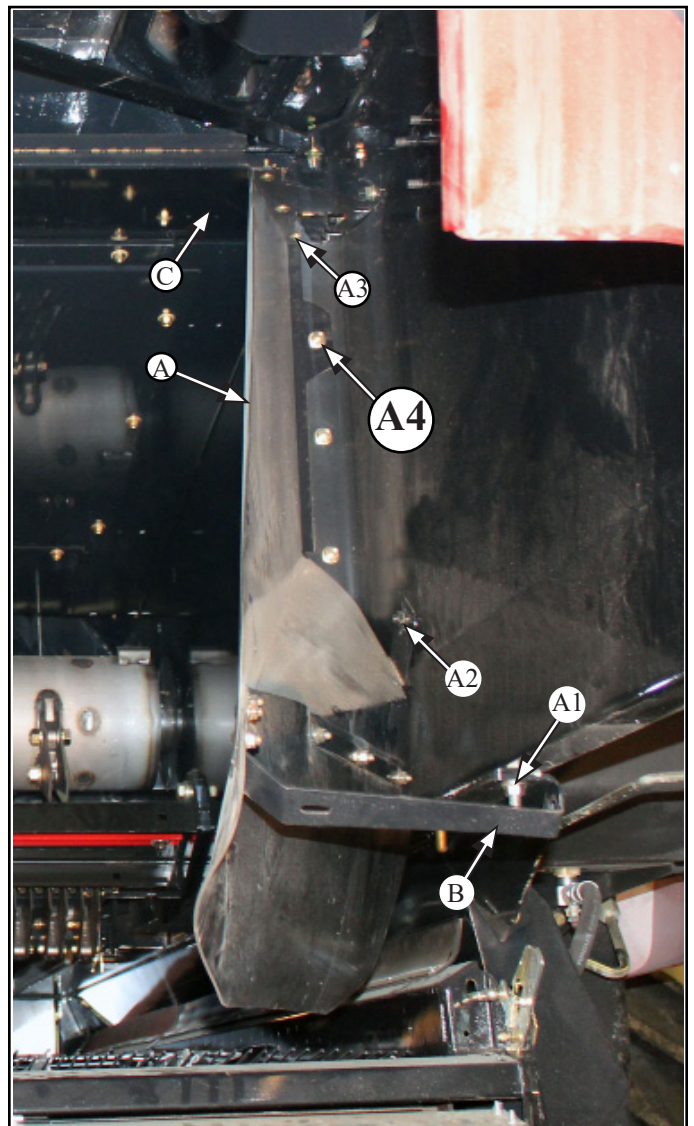

7 Sieve Extension Removal

7.1 Sieve Extension Removal

7.1.1 Remove center bolt hardware (**B1**) mounting the sieve extension arms (**A1**) to the pivot block (**B**) on the combine bracket - both sides

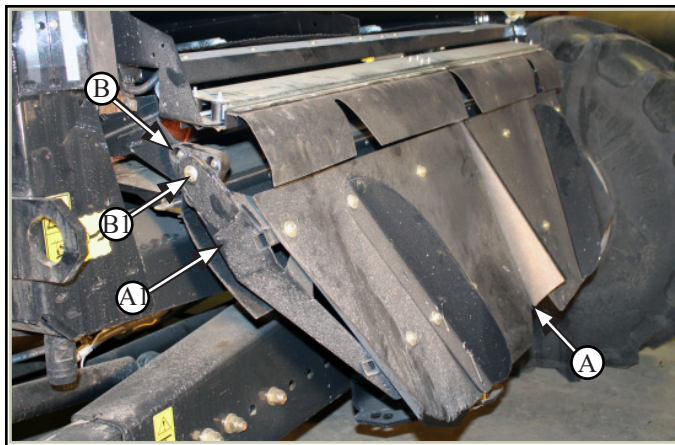

7.1.1.1 Turn Sieve Extension (**A**) over

7.1.2 Remove hardware (**C1**) mounting the rubber strap (**C**) to the sieve extension pivot bracket (**D**)

- not to be reused

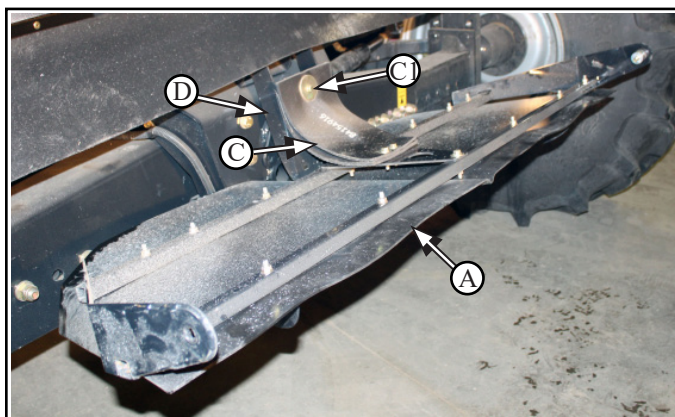

7.1.3 Remove hardware (**D1**) x2 mounting the pivot bracket (**D**) to the combine hitch frame (**E**)

- not to be reused

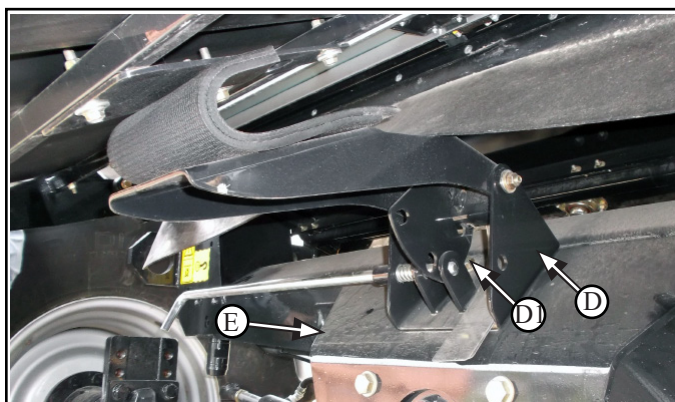

7.1.4 Remove hardware (**B2**) mounting the pivot tube blocks (**B**) to the combine bracket - both sides

- not to be reused

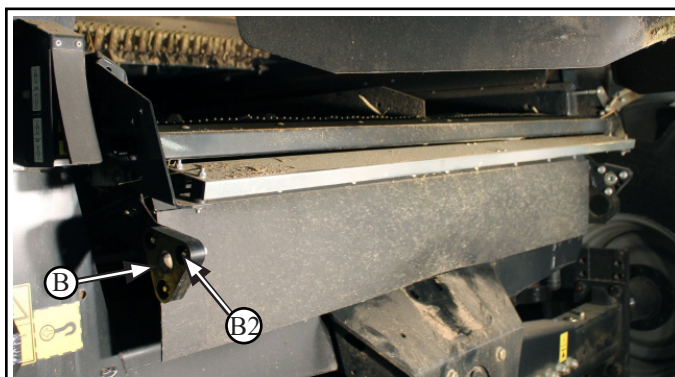

7.2 Sieve extension curtain assembly removal (if equipped)

7.2.1 Remove hardware (F1) x2 mounting the curtain assembly (F) to the underside of the grain loss monitor (G)
- both sides

- not to be reused

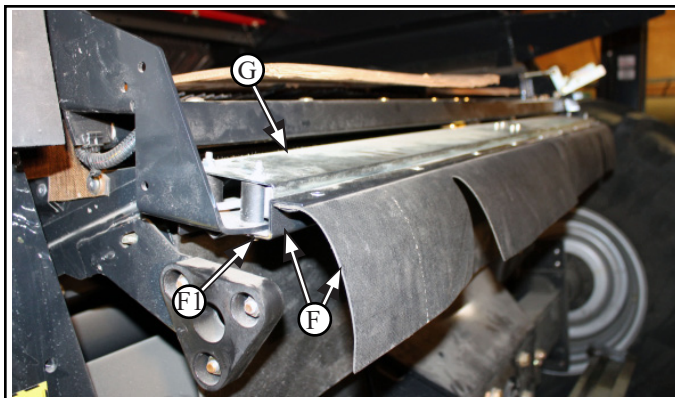
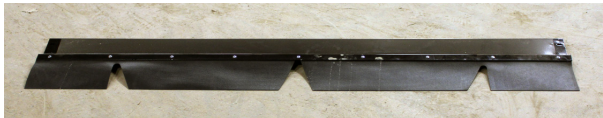

8 Hydraulic Oil Level



8.1 Check the hydraulic oil level before starting and moving the combine.

Oil level can be checked through the sight glass (A) located on the top rear deck. The oil level should at a minimum reach the bottom of the sight glass.

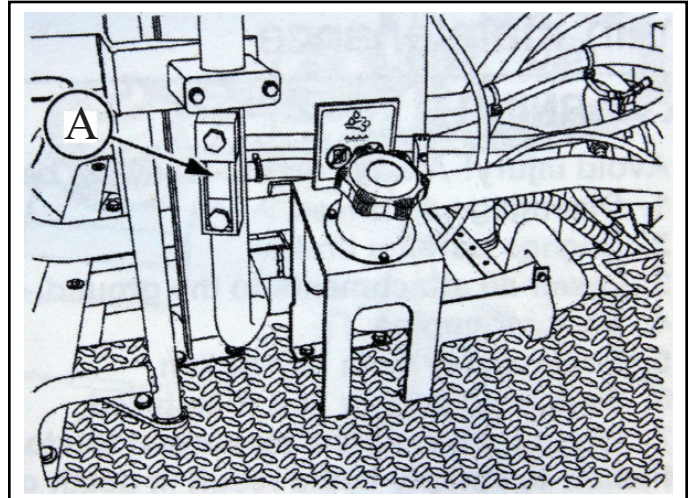

8.2 If necessary, add oil through filler opening (B)

Reference combine operator's manual for exact instructions

