



Case IH AFX  
MY17 Field Install  
Redekop MAV Straw Chopper Operator's Manual

# Case IH AFX 230 & 240 Series Redekop MAV Straw Chopper Operator's Manual

## Table of Contents

	<u>Section</u>
<b>0 Safety</b>	
Safety Instructions .....	0.1
Safety Decals .....	0.14
Information Decals .....	0.15
Serial Number .....	0.16
<b>1 Straw Chopper Operation</b>	
Knife Bar .....	1.1
Tailboard / Fins .....	1.2
Chaffboard .....	1.3
Chaff Belting Extension / Chaff Door .....	1.4
Straw Door Positioning .....	1.5
Internal Deflector Setting .....	1.6
Internal Straw Chopper Settings .....	1.7
Ladder .....	1.8
Windrow Roller .....	1.9
Drive Belt .....	1.10
<b>2 Straw Chopper Maintenance:</b>	
Bearing .....	2.1
Belt .....	2.2
Cosmetic .....	2.3
Straw Chopper Rotor Blades .....	2.4
Stationary Knife Blades .....	2.5
Combine Sieve Removal .....	2.6
<b>Troubleshoot</b> .....	<b>3</b>
<b>FAQ</b> .....	<b>4</b>

**Redekop Manufacturing 2014**  
 Box 178A, RR#4 Hwy 16 West  
 Saskatoon SK S7K 3J7  
 Ph: 1.306.931.6664  
       1.866.REDEKOP (1.866.733.3567)  
 Fax: 1.306.933.1088  
 Email: info@redekopmfg.com  
 Web: www.redekopmfg.com

# 0 Safety

## 0.1 Instructions

**0.1.1 IMPORTANT:** Read through this instruction manual thoroughly and familiarize yourself with the straw chopper before operating these components.

This instruction manual explains the proper procedure for operating the Redekop MAV Straw Chopper.



## 0.2 Recognize Safety Information

**0.2.1** This is a safety-alert symbol. When you see this symbol on your straw chopper or in this manual, be alert to the potential for personal injury.

Follow recommended precautions and safe operating practices.



## 0.3 Understand Signal Words

**0.3.1** A signal word - DANGER, WARNING, or CAUTION - is used with the safety-alert symbol. DANGER identifies the most serious hazards.

WARNING or CAUTION safety signs are located near specific hazards or precautionary areas in this manual.



## 0.4 Follow Safety Instructions

**0.4.1** Carefully read all safety messages in this manual and on your straw chopper. Keep safety signs in good condition. Replace missing or damaged safety signs. Be sure new straw chopper components and repair parts include the current safety signs. Replacement safety signs are available from your dealer.

There can be additional safety information contained on parts and components sourced from suppliers that is not reproduced in this operator's manual.

Learn how to operate the straw chopper and how to use controls properly. Do not let anyone operate without instruction.

Keep your straw chopper in proper working condition. Unauthorized modifications to the straw chopper may impair the function and/or safety and affect straw chopper life.

If you do not understand any part of this manual and need assistance, contact your dealer.

Other languages are available for this machine. Please contact Redekop.



## 0.5 Safe Operating Practices

**0.5.1** DO NOT stand near the straw chopper when combine is running.

ALWAYS refer to your Combine Operator's Manual, and review the Safety section before operating machine. The Combine Operator's Manual details safe operating practices that must be followed to protect you and others from accidental death and/or injury.

Operate straw chopper only when all guards are correctly installed.

Before moving away, always check immediate vicinity of straw chopper (e.g. for children). Ensure adequate visibility. Use a horn as a warning immediately before moving away.

When making turns, always take into consideration the width of the attachment and the fact that the rear end of the machine swings out. Attachments and ground conditions affect the driving characteristics.

Never leave combine unattended as long as engine is running.

## 0.6 Work In Ventilated Area

**0.6.1** Engine exhaust fumes can cause sickness or death. If it is necessary to run an engine in an enclosed area, remove the exhaust fumes from the area with an exhaust pipe extension.

If you do not have an exhaust pipe extension, open the doors and get outside air into the area.

## 0.7 Practice Safe Maintenance

**0.7.1** Understand service procedure before doing work. Keep area clean and dry.

Never lubricate, service, or adjust straw chopper while it is moving. Keep hands, feet, and clothing from power-driven parts. Disengage all power and operate controls to relieve pressure. Stop the engine. Remove the key. Allow machine to cool.

Securely support any straw chopper elements that must be raised for service work.

Keep all parts in good condition and properly installed. Fix damage immediately. Replace worn or broken parts. Remove any buildup of grease, oil, or debris.

On self-propelled equipment, disconnect battery ground cable (-) before making adjustments on electrical systems or welding on straw chopper.

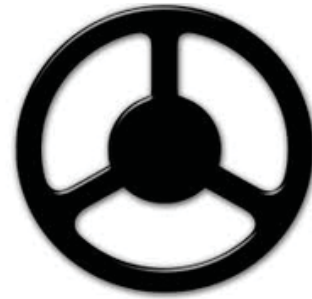

## 0.8 Avoid Contact With Moving Parts

**0.8.1** Keep hands, feet and clothing away from power driven parts. Never clean, lubricate or adjust straw chopper when it is running.



## 0.9 Avoid High-Pressure Fluids

**0.9.1** Inspect hydraulic hoses periodically - at least once per year - for leakage, kinking, cuts, cracks, abrasion, blisters, corrosion, exposed wire braid or any other signs of wear or damage.

Replace worn or damaged hose assemblies immediately.

Escaping fluid under pressure can penetrate the skin causing serious injury.

Avoid the hazard by relieving pressure before disconnecting hydraulic or other lines. Tighten all connections before applying pressure.

Search for leaks with a piece of cardboard. Protect hands and body from high-pressure fluids.

If an accident occurs, see a doctor immediately. Any fluid injected into the skin must be surgically removed within a few hours or gangrene may result. Doctors unfamiliar with this type of injury should reference a knowledgeable medical source.

## 0.10 Dispose of Waste Properly

**0.10.1** Improperly disposing of waste can threaten the environment and ecology. Potentially harmful waste includes such items as oil, fuel, coolant, brake fluid, filters, and batteries.

Use leakproof containers when draining fluids. Do not use food or beverage containers that may mislead someone into drinking from them.

Do not pour waste onto the ground, down a drain, or into any water source.



## 0.11 Use Proper Lifting Equipment

**0.11.1** Lifting heavy components incorrectly can cause severe injury or straw chooper damage.

Follow recommended procedure for removal and installation of components in the manual.

Ensure lifting equipment is rated for the job

Ensure operator is appropriately licensed to operate lifting equipment



## 0.12 Personal Protective Equipment (PPE)

**0.12.1** A Qualified Person designated by the employer, who is knowledgeable about and familiar with all relevant specifications and assembly instructions and is capable of identifying existing or potential hazards in surroundings or working conditions which may be hazardous or dangerous to employees shall determine appropriate Personal Protective Equipment required for this assembly.

Personal Protective Equipment (PPE) are devices worn by the employees to protect against hazards in the environment. Examples include safety glasses, face shields, respirators, gloves, hard hats, steel-toe shoes, and hearing protection.



## 0.13 Sound Level

**0.13.1** This product produces sound pressure levels in excess of 90 dB within 10m of discharge area.



Hearing protection is required!

Interference with speech communication, acoustic signals is possible.



0.14 Safety Decals

Hand Injury / Rotate Danger  
RP871



Projectile Hazard / Stand Clear  
RP872



Caution / Check Service Manual  
RP873



Keep Hands out of Belt Area  
RP874



**High Pressure Fluid Hazard / Check Service Manual**  
 RP876



**Pinch Point Hazard**  
 84394351



**0.15 Information Decals**

**Windrow Floor Adjustment**  
**Wide Spread / No Spread**  
 RP896

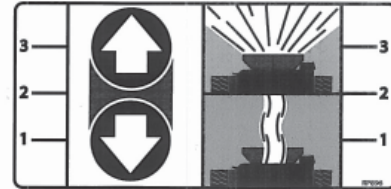

**Redekop Straw Chopper Serial Number Plate**  
 RP246



**Redekop Jackshaft Serial Number Plate**  
 RP927



**Knifebar Adjustment**  
 RP942

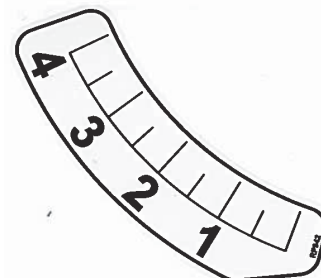



## 0.16 Serial Number

### 1. Rotor serial number (A):

- stamped on the rotor, located on the drive end

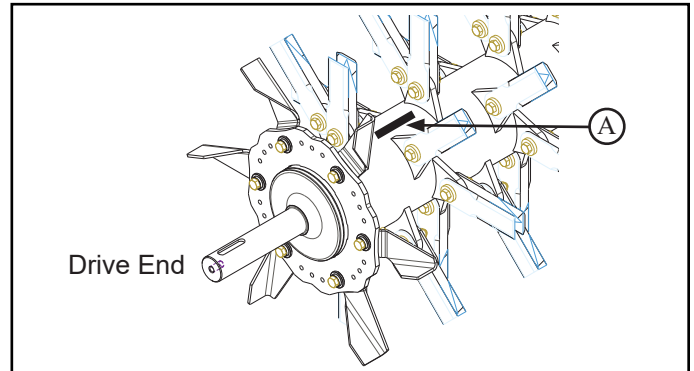

### 2. Straw chopper serial number plate (B):

- located on the chopper wall, non-drive side, below the rotor shaft shield



### 3. Jackshaft serial number plate (C):

- located on the top right corner of the jackshaft frame

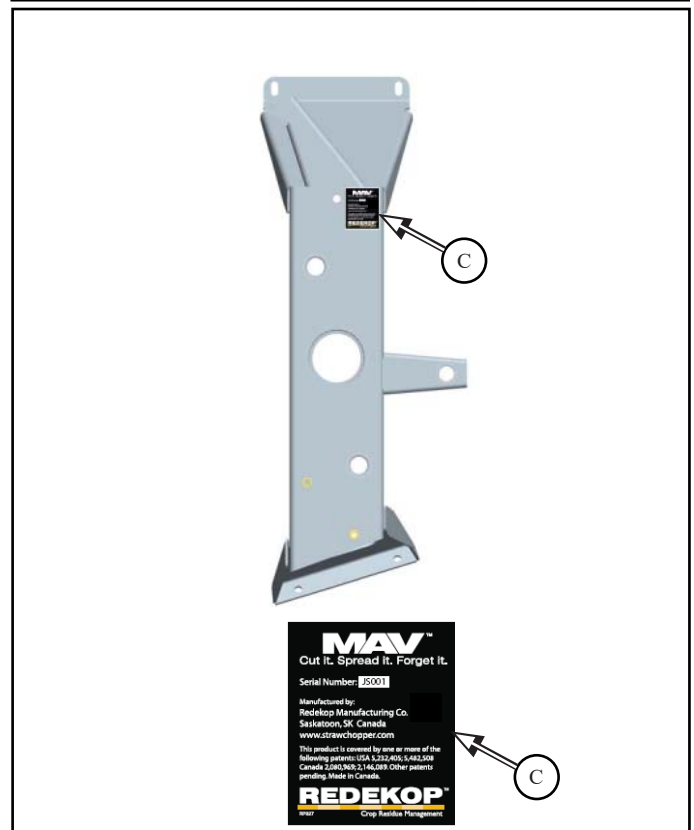

# 1 STRAW CHOPPER OPERATION

## General Information

The straw chopper residue management system may consist of the following components:

### Redekop MAV Straw Chopper (A)

- Cuts the straw into small manageable pieces and creates air velocity to spread this straw evenly across the field

### Stationary Knifebar (B)

- Assists in cutting the straw and determines the cut length of the straw

### Tailboard and Fins (C)

- Directs the cut straw out of the straw chopper in an even spread pattern across the field

### Chaffboard (D)

- Directs straw and chaff into the tailboard for even spreading across the field  
- Directs chaff only into tailboard for even spreading when straw windrowing

### Chaff Pan Extension and Chaff Door (E)

- Directs chaff from combine sieves into straw chopper

### Ladder (F)

- Provides access to the rear top platform on the combine

### Windrow Roller (G)

- Redirects the uncut straw onto the field in a windrow for baling

### Internal Deflector (H)

- Deflects straw evenly into the straw chopper

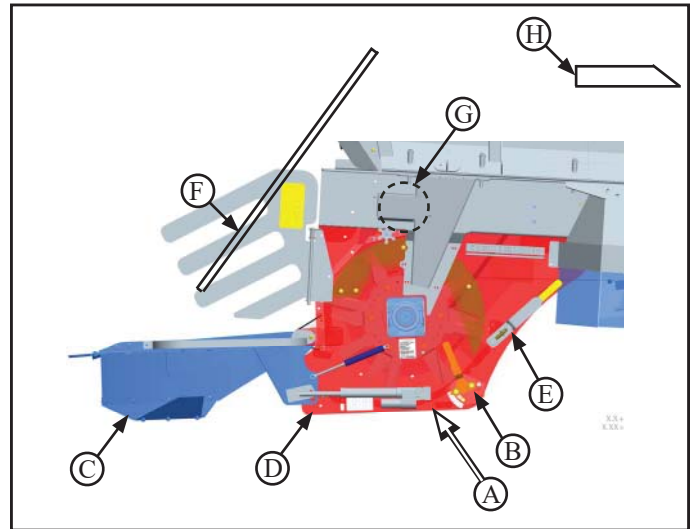

## 1.1 KNIFE BAR

**1.1.1** To adjust the depth of the stationary knifebar blades, loosen knifebar bolts (**A1**) on both sides of the straw chopper housing and use the handle (**A**) to position accordingly

- tighten bolts (**A1**) after desired position is obtained

- Arrow on handle (**A2**) points to indicator decal

- 0 indicates knifebar blades are all of the way out
- 4 indicates knifebar blades are all of the way in

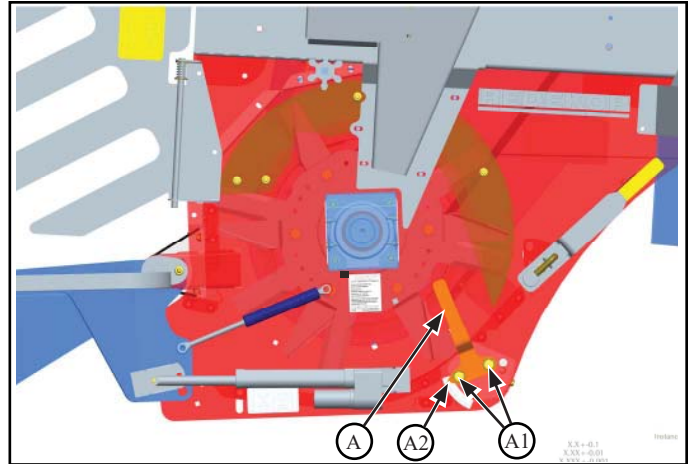

**1.1.2** Fine Cut - Pull handle (**A**) up to place stationary blades into the chopper housing as far as possible to get the finest cut - Position #4

**1.1.3** Coarse Cut - Push handle down (**B**) to place stationary blades outside the straw chopper housing if an extra fine cut is not needed - Position #0

**It is recommended to start with the knives completely out or at position #0. For a finer cut, move your knives in farther up to position #4. More horsepower is needed by the straw chopper to achieve the finest cut possible. Adjust to suit the cut desired.**

**1.1.4** Before tightening knife bar be sure the stationary blades are centered in the straw chopper floor slots

**1.1.5** Check for clearance of the rotor blades with the stationary blades by rotating rotor blades through the stationary blades

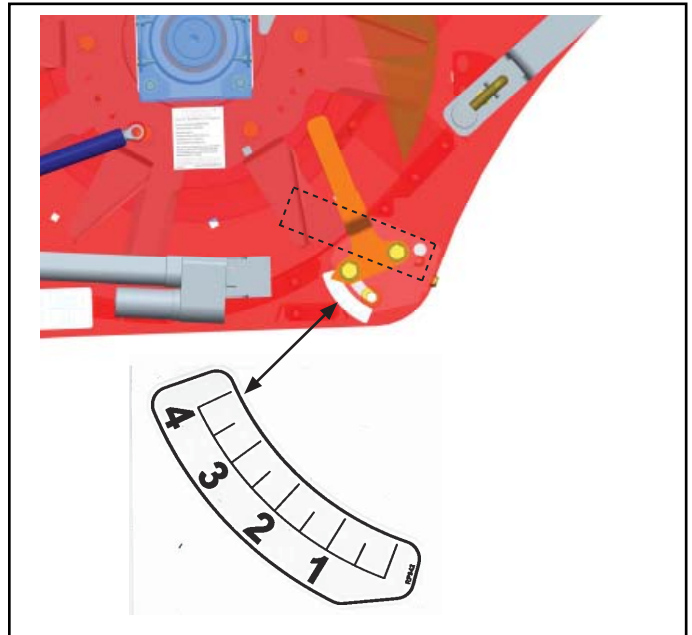

**CAUTION:** When chopping corn or sunflowers the knifebar blades **MUST BE AT POSITION #0 (ALL THE WAY OUT)** of the chopper housing and **ROTOR MUST BE RUN ON SLOW SPEED**

# CORN! SUNFLOWERS!

## 1.2 TAILBOARD / FINS

1.2.1 Position tailboard (A) to suit spreading requirements:

- Start with the highest position and reduce spread width by lowering the tailboard until desired width is achieved

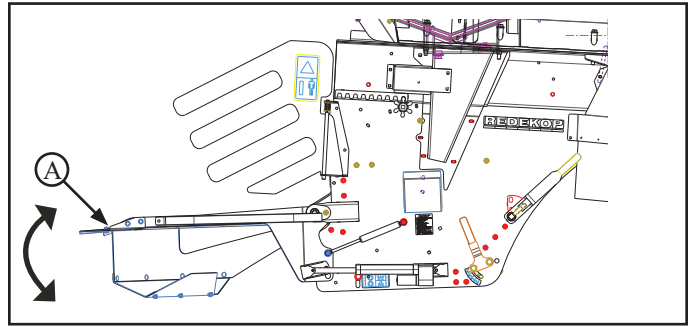

### Actuator Adjustment Option:

- Individual tailboard rotation can be controlled from the in cab vertical spreader control (C1 & C2)
- Left tailboard will be controlled by C1
- Right tailboard will be controlled by C2

Refer to the Combine Operator's Manual, working operations section, vertical spreader for further details on controls

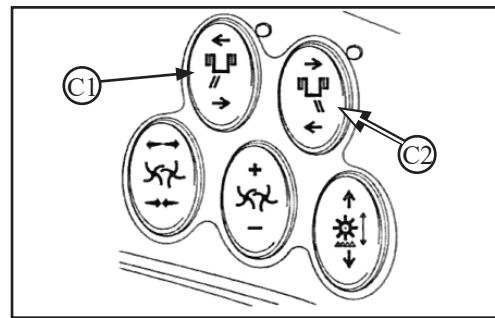

or

### Mechanical Adjustment Option:

- Individual tailboard rotation can be controlled by manually pulling the locking pin (K) out and rotating the tailboard to the desired location. Release the pin to lock the tailboard into place - ensure the pin is set into one of the notches in the adjustment lug (K1)
- Repeat for the other side

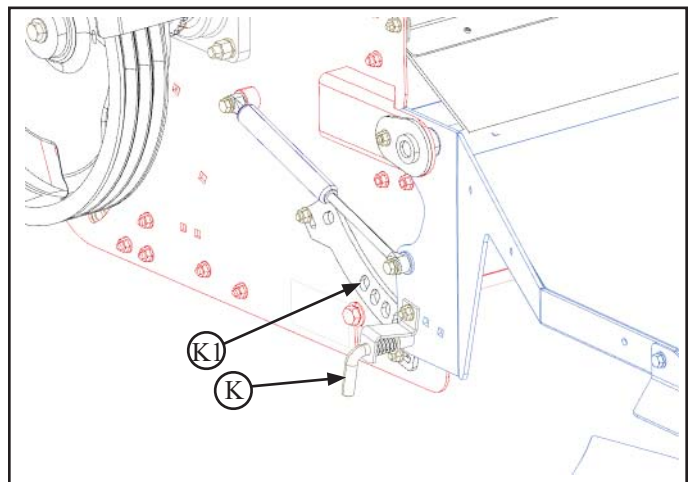

### 1.2.2 FIN POSITION

Position fins in the outer most edge of the slot for the widest spread and even distribution across the width of the cutter bar

If a narrow spread width is required (< 8m/26ft), pull all fins to their narrowest position. Reposition the front of the 3 outer fins to the square holes (D) and pull the back of the fins as far in as possible

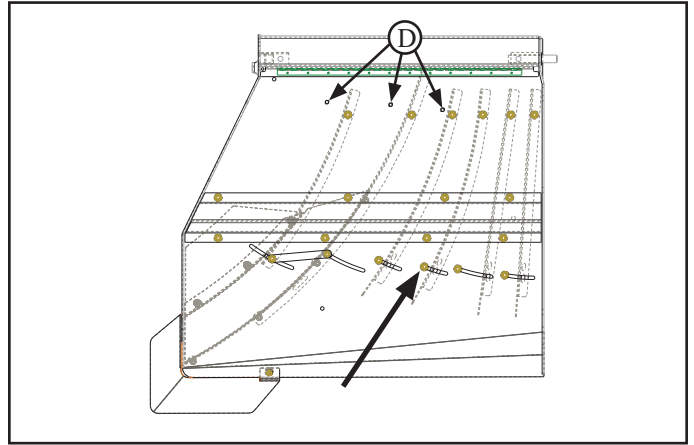

**1.2.3 FIN ADJUSTMENTS** - if uneven spread in field:  
- stand above chopper and observe straw from each fin landing in field. Rotate fins for even distribution

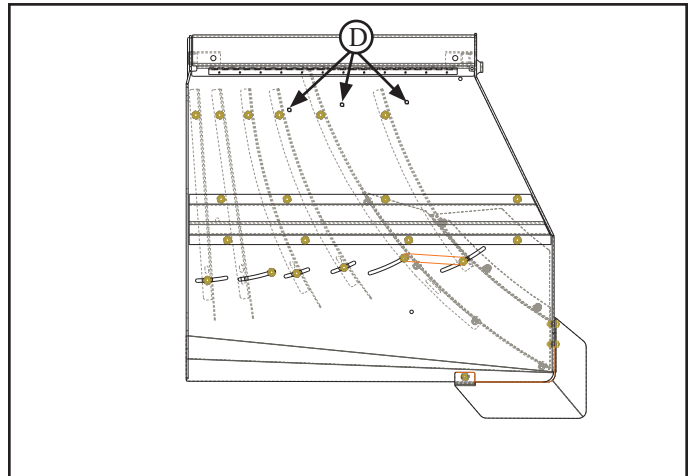

## 1.2.4 OPTIMIZATION OF WIDE SPREAD PERFORMANCE

1.2.4.1 Remove the link (E) connecting the small (F) and large fin (G) on top of the tailboard

 **Caution: Only adjust to increase spread width over max. setting.**  
Incorrect settings can create a reduction in spread width

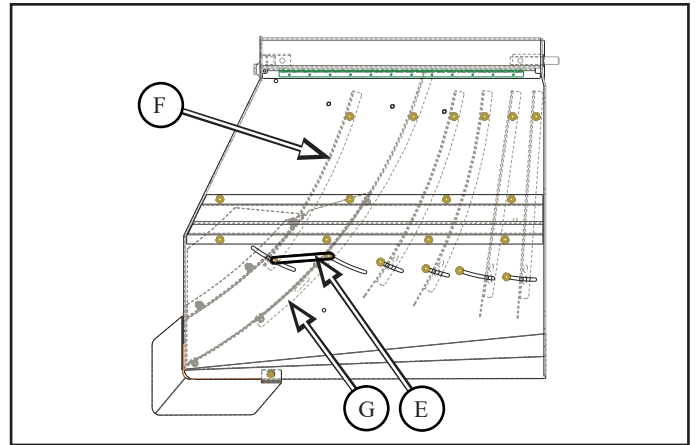

1.2.4.2 Adjust the small fin (F) to optimize the air flow (F1) merging with the straw (G1) coming off the large fin (G)

- a starting point is 300mm (12in) past the end of the tailboard
- Adjust both sides as necessary

 **Caution: Any further fin changes will require an adjustment to the outer fin**

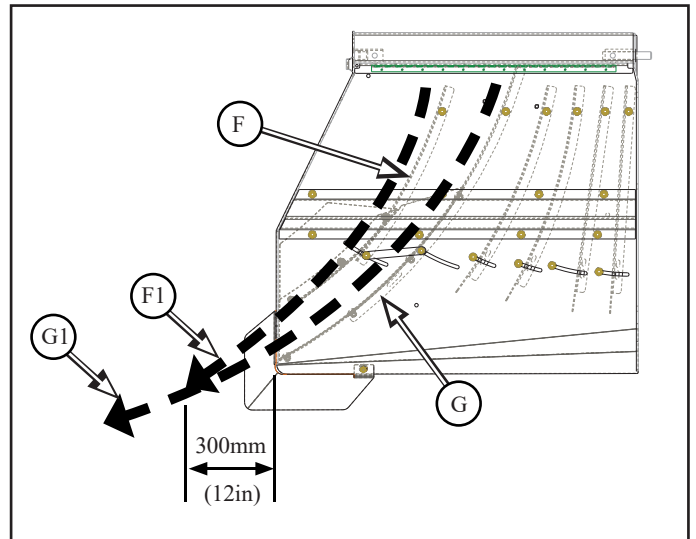

 **Caution: Incorrect setting can create Narrow Spread and Rowing**

1.2.4.3 If the air flow (F1) intersects (H) the flow from the large fin (G1), it will create a narrower spread and rowing

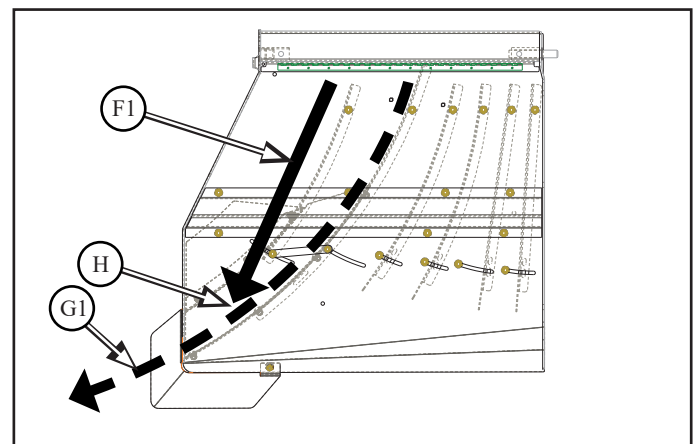

### 1.2.5 REAR WINDROW

**Step 1** - Set tailboard (A) at hole #3 or at a 30 degree position to windrow over the top of the chopper

Adjusting the tailboard upwards will take the momentum out of the straw and allow it to sit on top of the stubble. Adjust according to requirements

**Step 2** - Adjust finger assembly (B) to narrow or widen windrow as required

**Step 3** - Adjust chaffboard (C) to bottom

**Step 4** - Adjust knifebar (D) out

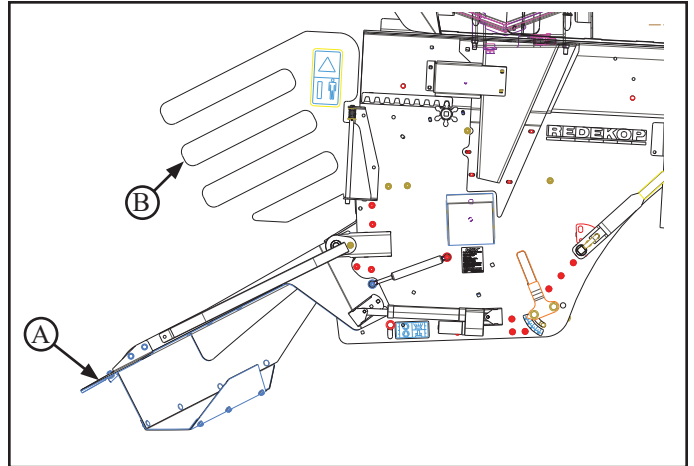

### 1.3 CHAFFBOARD

**1.3.1** To adjust the angle of the chaffboard (C), loosen the chaffboard adjustment bolts (C1) on both sides of the straw chopper housing - tighten bolts (C1) after desired position is obtained

#### 1.3.2 Chaffboard positioning:

Chop and spread straw  
- Pivot chaffboard (C) up - recommend starting at position #3

Windrow straw  
- Pivot chaffboard down - recommend all the way down

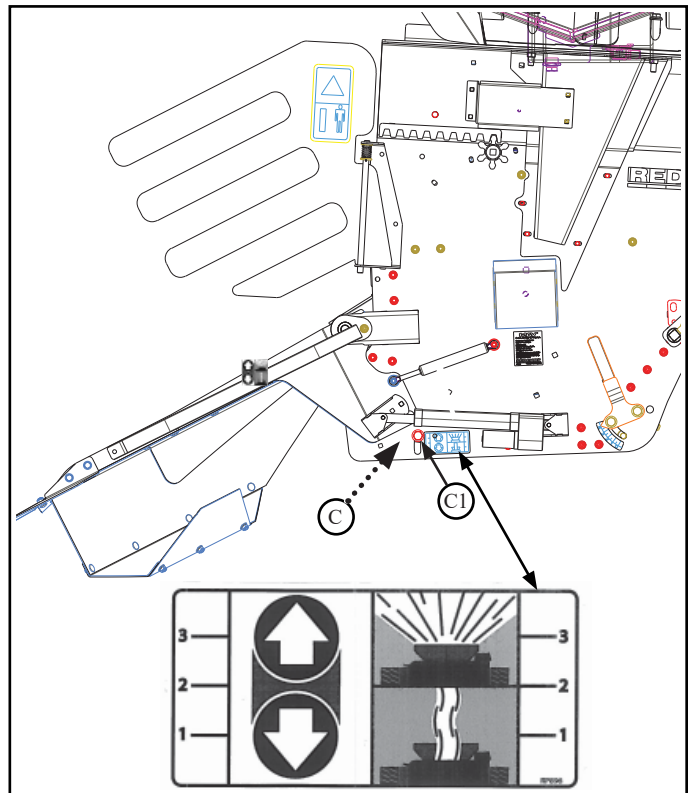

#### 1.3.3 Knifebar positioning:

Pivot knifebar (D) out when windrowing - position #0 - this will allow passage of stones or foreign materials with less damage than 100% engaged

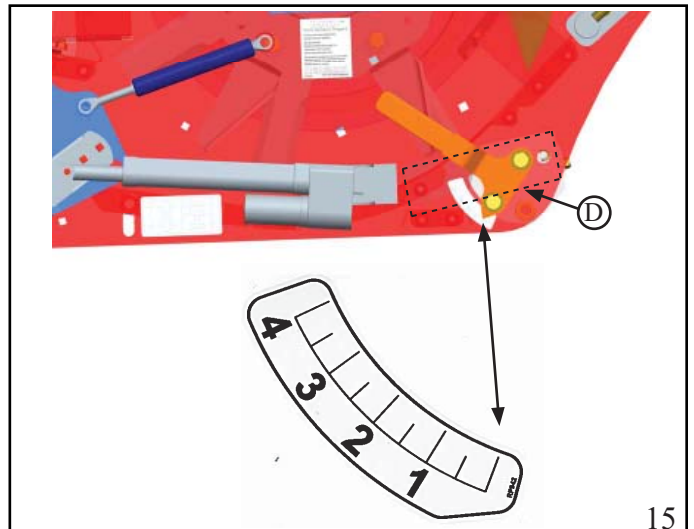



## 1.4 CHAFF BELTING EXTENSION / CHAFF DOOR

1.4.1 Ensure the chaff belting (A) is up and over the chaff door (B)

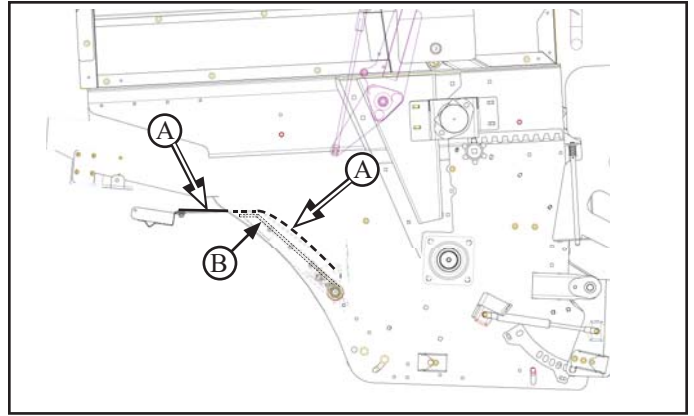

## 1.5 STRAW DOOR POSITIONING

Windrow:

Case IH AFX

### 1.5.1 Combines equipped with a windrow straw chopper

Direct straw over the back of the straw chopper (A) for windrowing. Chaff is spread by chopper

1.5.1.1 Open the straw door (B) with:

#### a) Mechanical Link

- Position the straw door (B) rearward with the handle (C) and lock in place (C1)

or

#### b) Actuator Adjustment

- Position the straw door (B) rearward with the factory electric actuator controlled by the remote switch (H)

1.5.1.2 Adjust the tailboard (D) and other components. Refer to 1.2.5 for further information

1.5.1.3 The hydraulic driven roller (F) that allows the straw to move smoothly over the back wall of the straw chopper will turn with the start of the threshing system

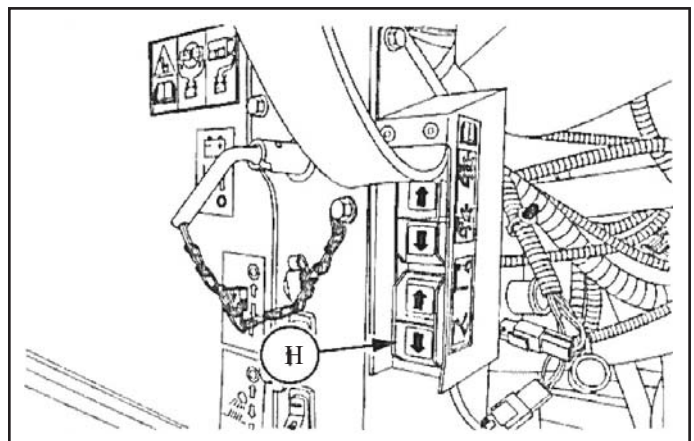
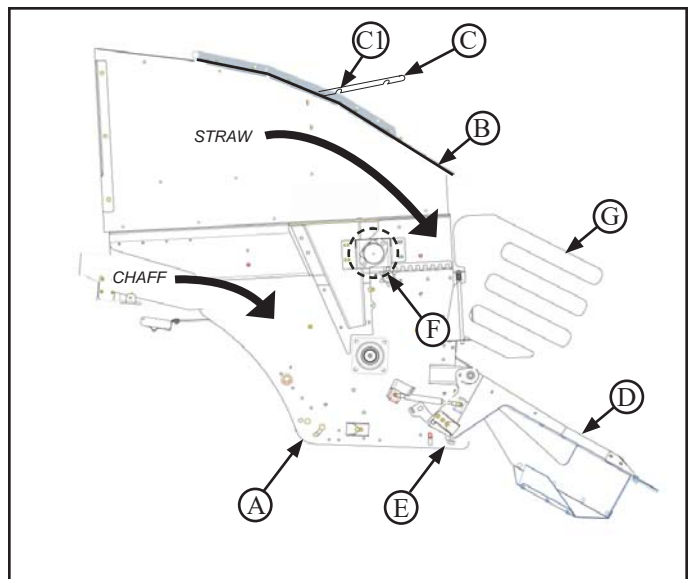



## 1.5.2 Combines NOT equipped with windrow straw chopper

### Case IH AFX

Direct straw and chaff in front of the straw chopper (A) for windrowing

**Step 1** - Slide chopper to rearward position - lock in place - refer to 2.6 for procedure

**1.5.2.1** Position the straw door (B) forward with the manual arm (C)

**1.5.2.2** Lock in position in the most forward position (D)

**1.5.2.3** Rotate the chaff door (E) up with the handle on the non drive side

**1.5.2.4** Drop the chaff belting (F) and allow straw and chaff to drop in front of the straw chopper

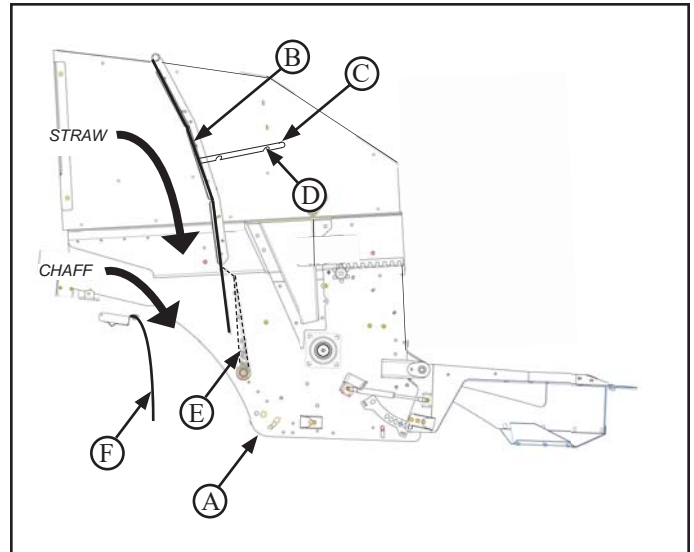

## 1.5.3 Chop straw

Direct straw through the straw chopper (A) for chopping and spreading

**Step 1** - Ensure chopper is slid forward - lock in place - refer to 2.6 for procedure

**1.5.3.1** Close straw door (B) - move rearward to seal against rear wall with:

### Manual Adjustment

- Position the straw door (B) forward with the manual lever arm (C), lock in position (C1) or

or

### Actuator Adjustment (if equipped)

- Position the straw door (B) forward with the factory electric actuator controlled by the remote switch (H)

**1.5.3.2** Pivot chaffboard (E) up - position 3 or 4. Refer to 1.3 for further information

**1.5.3.3** Move tailboard (D) up. Refer to 1.2.1 for further information

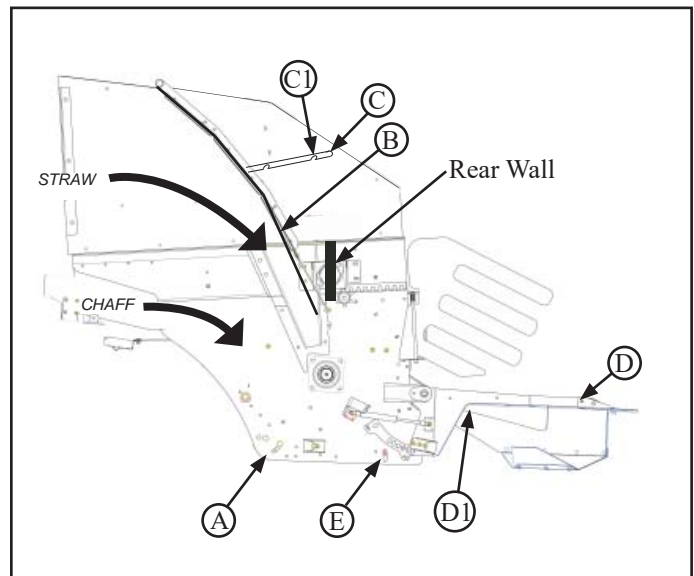

## 1.6 INTERNAL DEFLECTOR SETTING

The internal deflectors (**A**) are used to adjust and distribute straw evenly into the Redekop Straw Chopper

**1.6.1** Start with deflectors (**A**) set as shown:

- deflectors mounted to 2nd inside hole
- position left deflector aimed 150mm (6") inwards to left rear of chopper
- position right deflector aimed 300mm (12") inwards to left rear of chopper

This is the typical layout for most applications. Adjust angle, spacing of deflector to obtain even distribution

- Check distribution by windrowing. If the swath is even, the distribution into the straw chopper will be even

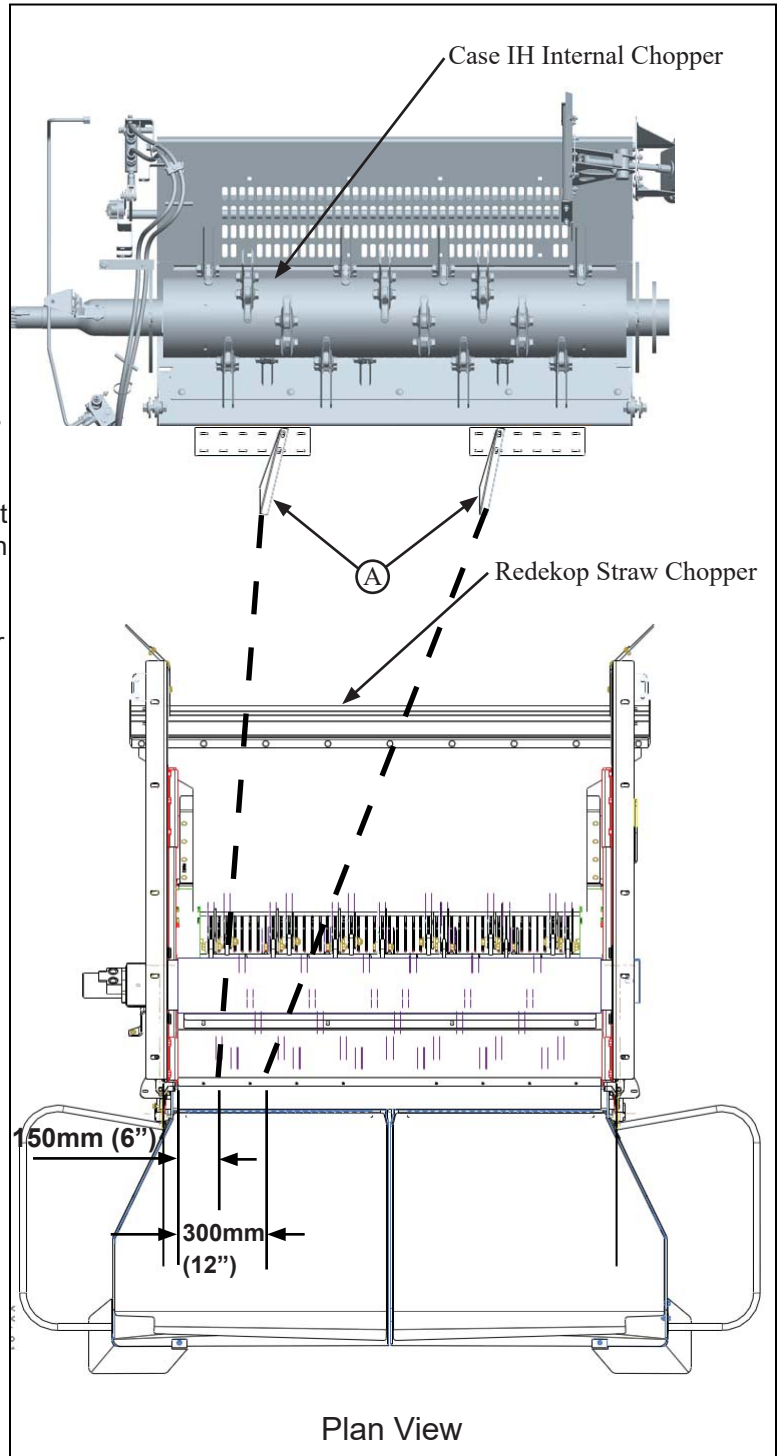

## 1.7 INTERNAL STRAW CHOPPER SETTINGS

### 1.7.1 Speed of internal straw chopper

The internal straw chopper can be operated in two (2) speeds

- High speed is required for all straw chopping operations **other than corn or sunflowers**
- Low speed is recommended for windrowing operation

Always follow your combine operators manual for exact instructions

### 1.7.2 Discharge Deflector

A fixed discharge deflector (**A**) is mounted on the right hand side of the threshing rotor discharge to direct material flow to the center of the residue system

The discharge deflector must be readjusted to be out of the material flow stream for even distribution across the full width of the Redekop straw chopper

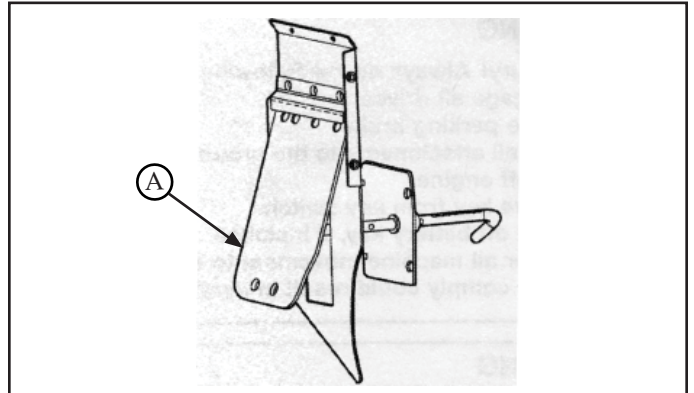

#### 1.7.2.1 Manual discharge deflector adjustment

The deflector should be retracted to the #1 position

- The adjustment handle (**B**) and pin are located on the right hand side of the combine, behind the clean grain elevator
- Unlatch and remove the D-pin to adjust the deflector
- Insert and latch the D-pin at the #1 position

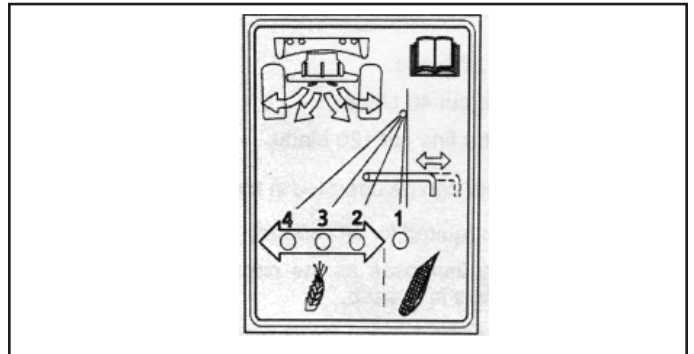
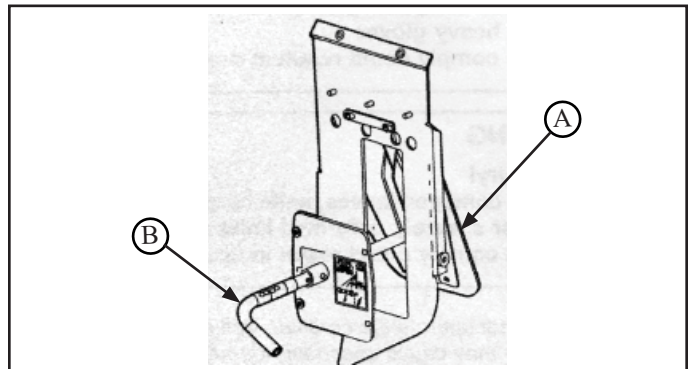

#### 1.7.2.2 Magnacut chopper discharge deflector adjustment

An in-cab control (**C**) positions the discharge deflector for even material flow into the Redekop straw chopper

- Depress the top side of the switch to move the deflector all the way out of the residue stream

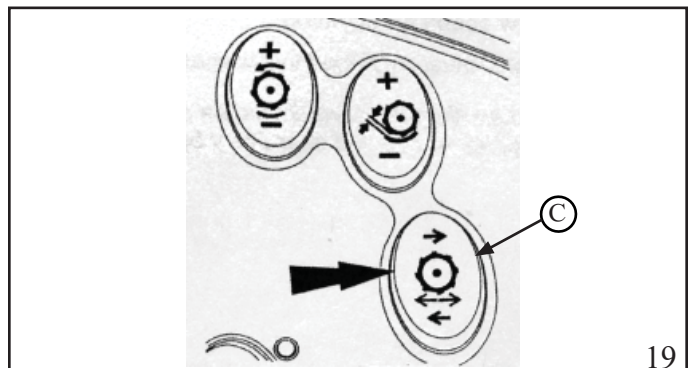

### 1.7.3 Internal counter knife adjustment

Internal counter knives (**A**) provide adjustment for internal straw chopping. The counter knives should be engaged 25% in most conditions (handle **B** in 2nd highest position) for best distribution into the Redekop chopper.

#### 1.7.3.1 Manual adjustment

- The counter knife adjust handle (**B**) is used to vary the height of the counter knives.
  - With the handle down, the knives are fully engaged
  - With the handle up, the knives are fully disengaged
- Adjust the handle (**B**) up to engage the knives 25% in most conditions
- Ensure the handle is locked into one (1) of the adjustment notches (**B1**)

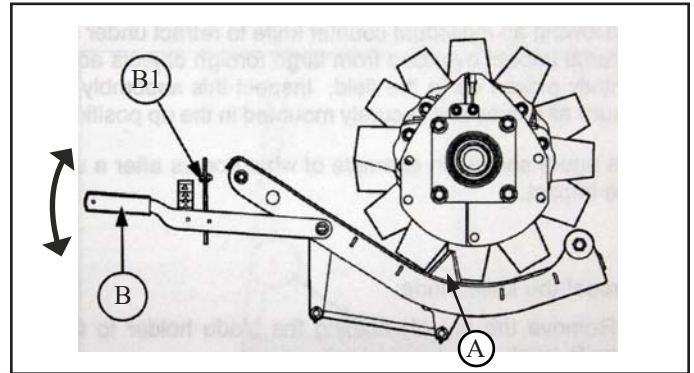

- The knives must be fully disengaged (handle up in highest position) in corn or sunflowers

#### 1.7.3.2 Magnacut chopper counter knife adjustment

An in-cab control (**C**) has five (5) preset positions, from not engaged to fully engaged

- Adjust the counter knives to engage the knives 25% in most conditions

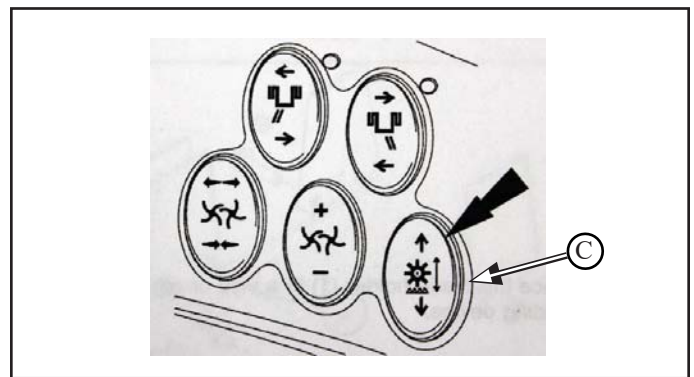

- The knives must be fully disengaged in corn or sunflowers

When retracting the knives, the system will retract the knives completely

### 1.7.4 Internal concave floor adjustment

The concave below the internal chopper is spaced to provide additional straw chopping adjustment. The tighter the space between the concave and internal chopper blades, the more power required, but better cutting and distribution into the Redekop chopper.

In most conditions with the Redekop straw chopper, the space between the concave and internal chopper knives can remain at factory setting of 10mm.

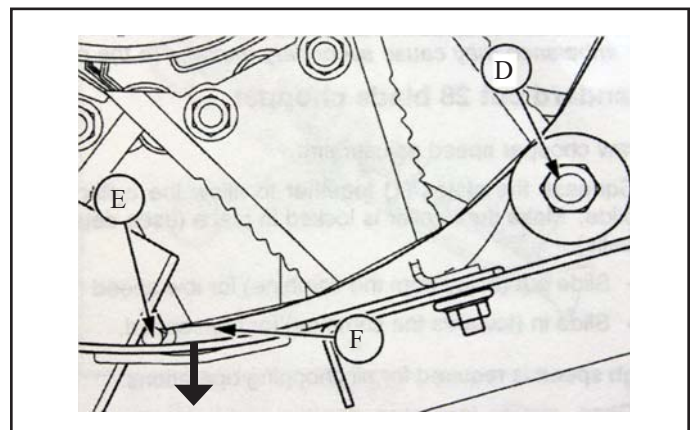



## 1.8 LADDER OPERATION

1.8.1 To move ladder (A) down:

1.8.1.1 Rotate tailboards (B) down into lowest position. Refer to 1.2 for further information

1.8.1.2 Pull handle (A3) down on ladder

1.8.1.3 Pull pin (A2) on lower ladder extension and rotate down until roller sits on tailboard and locks in place



1.8.2 To move ladder (A) back in the upward position

1.8.2.1 Pull pin (A2) on lower ladder extension (A1)

1.8.2.2 Rotate lower ladder (A1) up until it locks into position on the main ladder (A)

1.8.2.3 Rotate main ladder (A) up into vertical position

1.8.2.4 Adjust angle of tailboards (B) back to working position



1.8.3 Always store ladder (A) in the upward position when operating the straw chopper



### 1.9 REAR WINDROW ROLLER (A) speed adjustment

In most cases, the factory speed setting is acceptable. If required, adjust speed of rear windrow roller to suit straw discharging from the combine

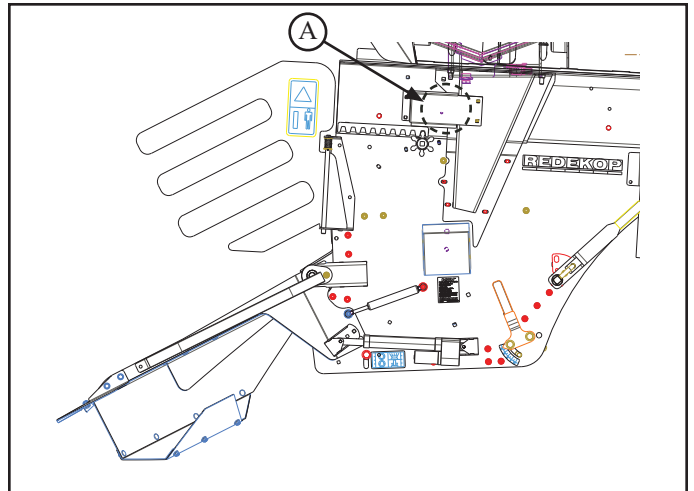

1.9.1 Rear windrow roller (A) speed can be adjusted from the in cab vertical spreader control (A1)

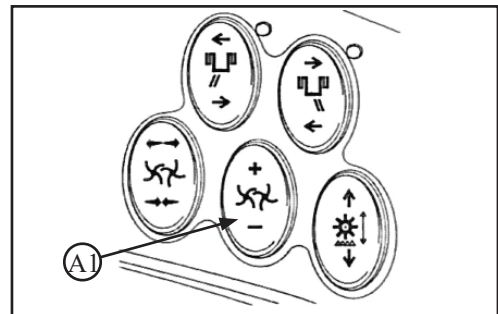

### 1.10 DRIVE BELT

1.10.1 To access the drive belts, remove drive belt shield (A)

- Reinstall after all belt adjustments have been made

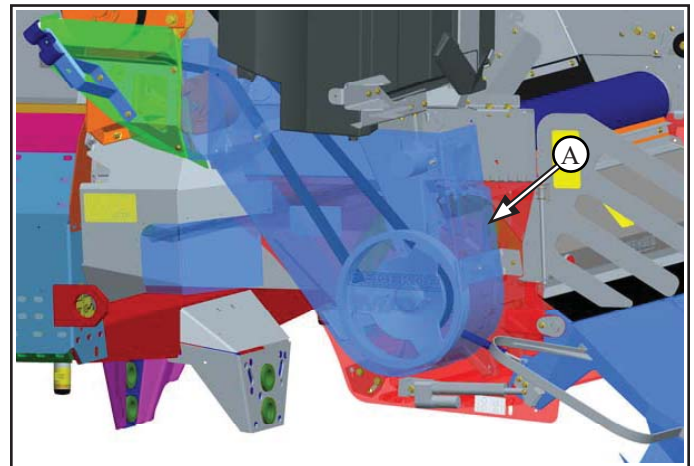

1.10.2 To adjust upper drive belt (B) tension:

- Tighten or loosen top tension link (B1)

1.10.3 To adjust lower drive belt (C) tension:

- Tighten or loosen lower tension link (C1)

1.10.4 To remove upper drive belt (B):

- Loosen top tension link (B1)

1.10.5 To remove lower drive belt (C):

- Loosen lower tension link (C1)

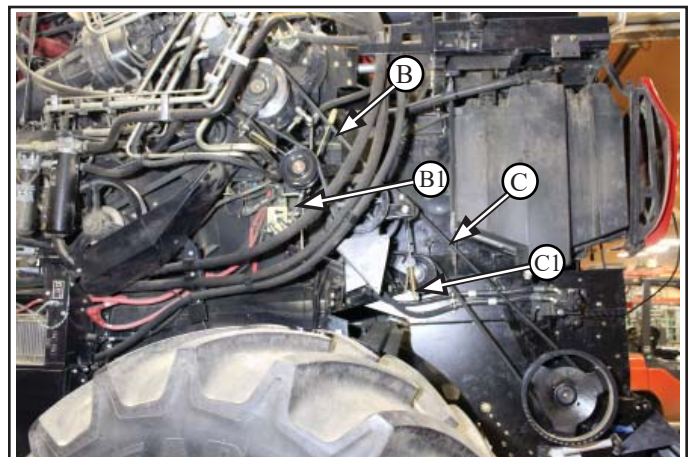

## 2 STRAW CHOPPER MAINTENANCE

Although little active maintenance is required to keep your Redekop MAV Straw Chopper operating smoothly, it is very important that the following preventative maintenance schedule be followed. A regular visual check and replacement of the high wear components will prevent larger scale maintenance in the future. The following areas of your straw chopper and rotor should be checked on a regular basis.

### 2.1 BEARINGS

**Recommended Service Interval - Life Time**  
**\*\* DO NOT LUBRICATE \*\***

DO NOT LUBRICATE. Bearings come pre-greased, there is no requirement to grease.

### 2.2 BELT

**Recommended Service Interval - 70 hours - Weekly**

**2.2.1** If excessive belt temperatures are evident, or the straw chopper seems to be losing excessive rpm during operation in tough or heavy conditions, the belt tension is not sufficient and should be adjusted immediately

**2.2.2** Look for cracks, frayed edges, or any imperfections that may result in breakage

- if a belt edge shows excessive wear, check for mis-alignment of the pulleys and correct if necessary

### 2.3 COSMETIC

**Recommended Service Interval - 10 hours - Daily**

**2.3.1** Clean off residue from top of tailboards to prevent excess moisture from collecting

**2.3.2** Set angle of tailboards down to allow moisture to run off when combine is not in use

### 2.4 STRAW CHOPPER BLADES

**Recommended Service Interval - 10 hours - Daily**

**2.4.1** Look for excessive wear of metal, cracks, or other visible damage and replace as necessary

**2.4.2** Check clearance between the blades and stationary blades to ensure that there is adequate space to operate without obstruction

- there should be no less than 4mm / 5/32in of clearance between each blade edge and the closest stationary blade
- clearance problems may occur when blades and/or stationary blades may be deformed by hard objects that pass through the combine - check for and replace components as necessary
- repetitive ticking or knocking sounds emitted from the straw chopper may signal a minor clearance problem - the straw chopper should be stopped immediately and examined

**CAUTION!** If one (1) blade breaks and the straw chopper must be operated without a replacement, then remove the damaged blade and the blade on the opposite support (180 deg). Also, remove the two (2) blades at the other end of the rotor, at the same axial distance from the balance ring.



**CAUTION!** Never replace only one (1) blade for wear or breakage. Eight (8) blades **MUST** be installed to replace one (1) broken blade, or all the blades replaced at one time. This **MUST** be done to keep vibration to a minimum.

### 2.4.3 Rotor Blade Installation Procedure

**IMPORTANT!** The fan blades, located on the balance rings inside the chopper, must be installed in the direction shown (A). The straight edge of the blade cuts the air while the paddle trails behind and pushes the air.

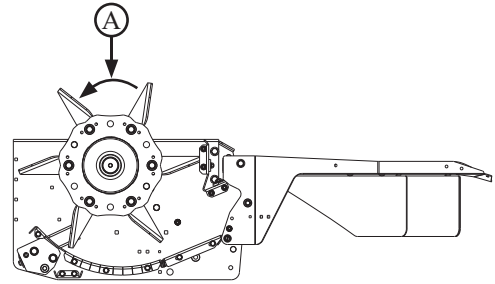

The blades for your straw chopper must be installed as outlined.

**Note:** If blades are installed other than as directed, damage to the straw chopper may result or performance may be significantly reduced.

**IMPORTANT!** Straw Chopper Rotor balance **MUST** be maintained.

**2.4.3.1** Replace **BOTH** blades on single support and **BOTH** blades opposite support (180 deg). Also, replace the four (4) at the other end of the rotor, at the same axial distance from the balance ring.

**Eight (8) blades MUST** be installed to replace one broken blade, or all the blades can be replaced at one time. This **MUST** be done to maintain dynamic balance, and to keep vibration to a minimum.

**2.4.3.2** If a blade breaks and the chopper must be operated without a replacement, then the damaged blade and the one directly opposite and the corresponding blades on the opposite end of the rotor must be removed to maintain rotor balance. A total of four (4) blades to be removed.

Use only METRIC class 10.9 bolts (B) and class 10 DIN980V all steel lock nuts (F) on the straw chopper rotor

Ensure at least two (2) threads are shown after tightened

Use a torque wrench to tighten all nuts to the recommended values:

- M10 nuts to 40 ft-lbs or 55 Nm
- M12 nuts to 50 ft-lbs or 65 Nm

**2.4.3.3** Always check for adequate clearance between the installed blades and the stationary knives. A minimum of 4mm or 5/32in is required. Check clearance of all blades, even those that are not replaced. Do not operate the straw chopper unless this clearance is maintained for all blades

**2.4.3.4** Assemble blade pairs as per order shown (B to F)

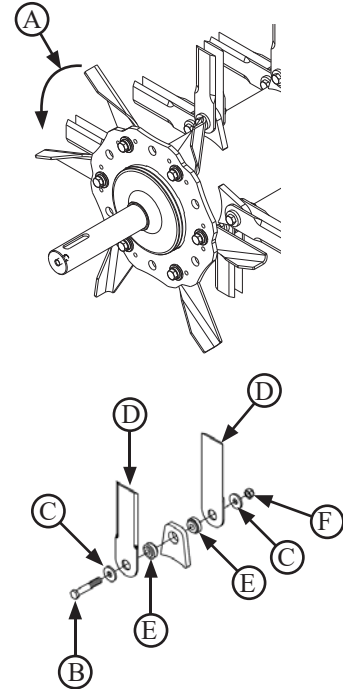

- A - Blade direction
- B - Hex Bolt
- C - Washer
- D - Rotating Blade
- E - Bushing
- F - Lock nut



**CAUTION:** Always use METRIC class 10.9 bolts and matching class 10 all steel lock nuts when installing blades.



**CAUTION:** Ensure at least two (2) threads are showing beyond the nut after tightening.

Note: Torque values listed are for chopper blade installation only. DO NOT use these values for different procedures or applications.



## 2.5 STATIONARY KNIFE BLADES

Recommended Service Interval - 10 hours - Daily

**2.5.1** Check stationary knife blades **(A)** for excessive wear, damage, or breakage

**2.5.2** If a stationary knife blade breaks:

- remove the backplate **(B)**
- remove the rod **(C)** holding the blades in place
- replace the damaged blade **(A)**
- reinsert the rod **(C)**
- reinstall backplate **(B)**

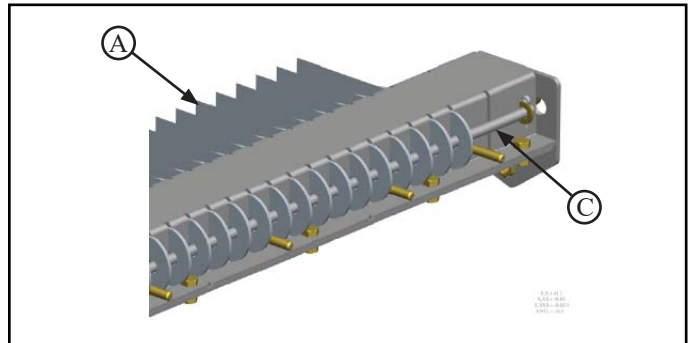
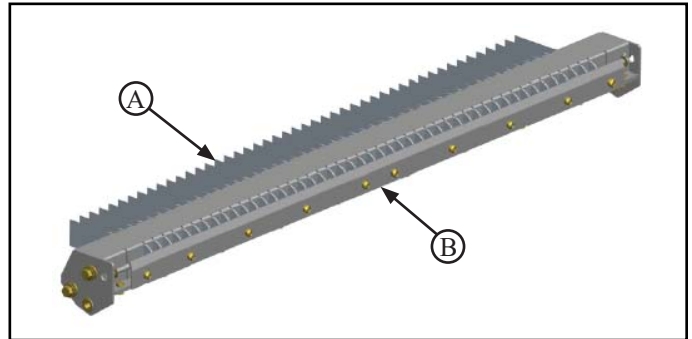

## 2.6 COMBINE SIEVE REMOVAL

### 2.6.1 Remove belt guard (B)

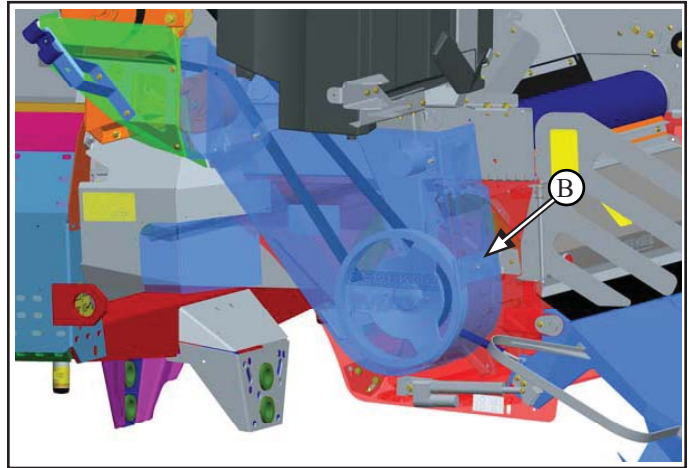

### 2.6.2 Loosen belt tensioner (C1) and remove belt (C)

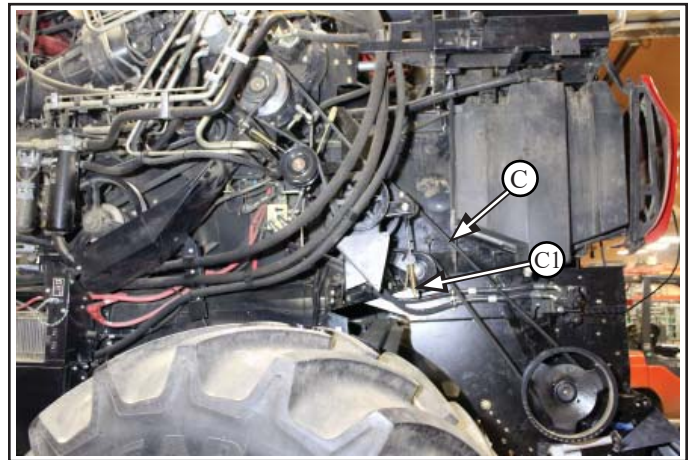

### 2.6.3 Remove bolt (D1) mounting vent (D) to side of chopper wall (A) - both sides

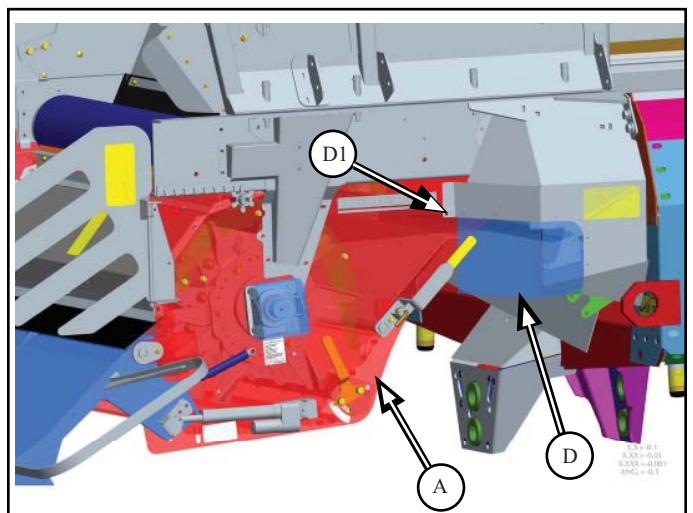

**2.6.4** Remove bolts (**E1**) x4 from bottom support plate (**E**)

- both sides

**2.6.5** Remove slide bolts (**F1**) x2 from top slide plate (**F**)

- both sides

**2.6.6** Rotate slidegear sprocket (**G**) to slide chopper back

**2.6.7** Remove locking bolt (**H1**) from handle (**H**)

**2.6.8** Rotate the chaff door (**F**) up using the handle (**H**) on the side of the straw chopper (**A**)

**2.6.9** Pull the chaff belting (**K**) down

**2.6.10** Remove sieves

**2.6.11** After adjusting, place all components back to their original position to close off access to the sieves

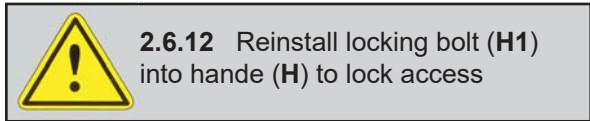

**2.6.13** Reinstall bolts (**E1**) x4 into side support plate (**E**) - both sides

**2.6.14** Reinstall slide bolts (**F1**) x2 into top slide plate (**F**) - both sides

**2.6.15** Reinstall vent (**D**) to side of chopper wall - both sides

**2.6.16** Reinstall belt (**C**) and tighten belt with tensioner (**C1**)

**2.6.17** Reinstall belt guard (**B**)

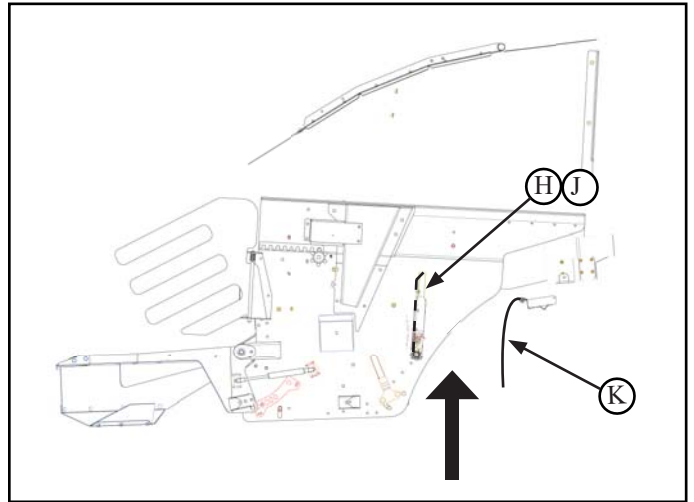
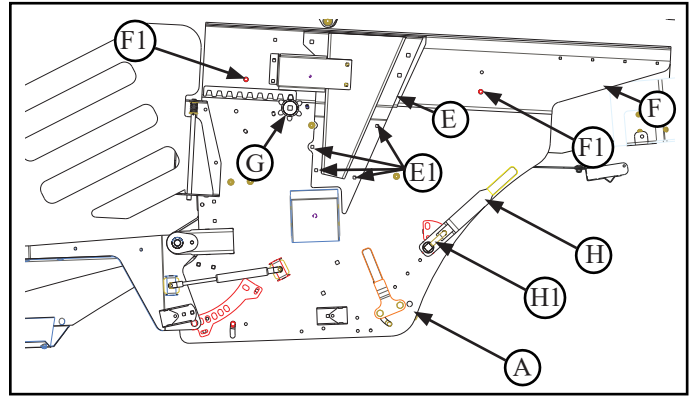

## 3 TROUBLESHOOT

### 3.1 Broken blade?

If a blade breaks due to a foreign object coming through the straw chopper, always replace blades eight (8) blades at a time. Refer to section 2.5 for replacement blade procedure. **Never replace only one blade for wear or breakage.**

### 3.2 No spare blade replacement available?

If a blade breaks and the straw chopper must be operated without a replacement, then the damaged blade and the one directly opposite and the pair on the opposite end must be removed to maintain rotor balance.

### 3.3 Is a knocking sound heard when starting up the chopper?

Check for adequate clearance between the installed blades and the stationary blades. A minimum of 4mm or 5/32" is required. Check clearance of all blades, even those that are not replaced. Do not operate the straw chopper unless this clearance is maintained for all blades.

### 3.4 Insufficient clearance of straw chopper rotor blades past the stationary blades?

Check that the stationary blades are centered in the middle of the slots in the straw chopper floor. If they are not, the knife bar must be moved over.

### 3.5 Still insufficient blade clearance?

If you do not have sufficient clearance and the stationary blades are in the position specified in point #3.3, the rotor must be moved over. Remove all shields to access the rotor bearings and loosen bolts. Shift the rotor over slightly and check for blade clearance. Retighten bolts making sure the rotor does not get pulled over to one side in the process. Retorque bolts to specifications.

### 3.6 Not cutting properly or straw plugging in front of chopper?

Check your rotor blades for wear and flip or replace them if necessary. Tough conditions will also play a factor in how well the straw chopper is or isn't cutting.

### 3.7 Is there rowing behind your straw chopper?

Adjust the tailboard fins. Check that the internal deflector fins are positioned correctly so that all residue will be evenly distributed across the width of the chopper. Single rotary combines must have the straw redirected before it reaches the straw chopper to accomplish even spread. In most cases, rowing results because the straw from the 2nd and 3rd fin from the outside lays straw on top of that from the outside fin. Stand above chopper in a safe place and observe distribution. Adjust fins as necessary.

### 3.8 Are your drive belts slipping?

Make sure the drive sheaves are aligned and check the tension of your belt. If the belts are too loose you'll get insufficient traction and wear the belts; if the belts are too tight there will be excess wear on the belt and on the sheave; check for sheave wear. If the sheaves are aligned and the belts are not worn, check for wear on the sheave as the next possibility.

### 3.9 Is there chaff / grain embedded in the drive belt?

Determine where the chaff is coming from and redirect chaff flow away from the belt.

## 4 FAQ

### 4.1 How long do the blades last?

A: It varies drastically due to cutting conditions, crop conditions, soil types, etc.. The typical life of a heat treated blade is approximately 200 hours. The carbide coated blade has a life approximately 1.5x the life of the heat treated blade.

### 4.2 What is the difference between the standard heat treated blade and carbide coated blade?

A: The carbide coated blade has a carbide coating on one side of the blade and will continue to create a sharp edge as it wears and cut more efficiently. The non carbide coated blade will dull and round off after a few hours.

### 4.3 How does the straw chopper perform in flax and soybean and corn?

A: The blades will wear faster in these crops, but with carbide coated - self sharpening blades, they will hold their edge and cut more effectively through flax and soybeans. However blades will wear faster in these crops. It is recommended that blades be in a sharp condition when chopping flax. **In corn the chopper MUST run at a slower speed. The stationary blades must be pulled out of the chopper housing** while only the rotor blades dice up the husks and stocks.

### 4.4 Does the straw chopper rotor need to be rebalanced each time you need to replace blades?

A: No, by replacing the blades as per section 2.5 or replacing **ALL** of the blades, the rotor should be fully balanced.

### 4.5 Any special requirements for chopping corn?

A: Yes, the straw chopper **MUST** run at a slower speed (800-1200 rpm) and the stationary blades **MUST** be pulled completely out of the straw chopper housing.

### 4.6 How much horsepower does the straw chopper need to run?

A: Horsepower requirement is related to type and volume of straw, as well as moisture conditions. As a result it will vary continually. On any given day the same chopper could require as little as 20hp or upwards of 100hp.

### 4.7 How far does the straw chopper spread?

A: Under ideal conditions the straw chopper will spread up to 40 feet/12m. To accomplish this, the straw chopper must be adjusted to cut medium length straw, it must be running full, and it must be fed uniformly, especially to the outsides. The straw chopper can spread as narrow as 20-25 feet. To accomplish this the tailboard fins must be adjusted and the tailboard should be lowered considerably.

### 4.8 Can I spread the chaff with the straw?

A: Yes, with straw and chaff model choppers. Customers ordering a Redekop MAV straw only chopper does not take the chaff into the chopper to be spread. In those cases the factory chaff spreader systems must remain intact. Most rotary type combines can be fitted to take in both straw and chaff with one of our new Redekop MAV choppers.

### 4.9 Do the Redekop blades fit into all factory choppers?

A: No, you must have a Redekop Straw Chopper or a Redekop Upgrade Rotor to use the Redekop blades. Update kits are available for other combine blades. Contact your Redekop dealer for more information.